

Cosmic

ผู้ผลิตและจำหน่ายเครื่องมือ อุปกรณ์ในการสร้างแม่พิมพ์

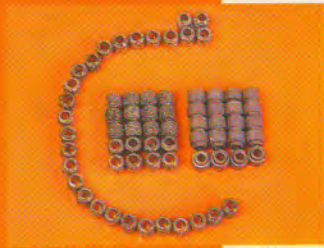



เม็ดเพชรตัดหินอ่อนและแกรนิต
Bead for wire saws



หินเจียรเพชรขอบบัว
Diamond wheel for stone craft



ใบเลื่อยตัดและแกะสลักหิน
Handy cutters



จานเพชรแต่งหน้าหิน
Cup wheels (Segment)

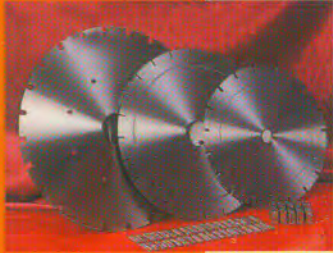

ใบเลื่อยตัดหินและคอนกรีต
Saw blade



ใบตัดชุบเพชร
Diamond electroplated cutter



จานเจียร เพชรและ CBN
Diamounted & CBN grinding wheels



เพชรแต่งหิน
Dressers



หัวเจียรแกะสลักแกน 6 มม.
Carving mounted wheel



กระบอกเจาะกระจก
Core drill glass



กระบอกเจาะเพชร
Core drill bits



แผ่นเจียรเพชร
Lapping Discs



มีดกลึงเพชร
PCD & PCBN turning bits



แปรงขัดเพชร
Diamond hand stone



ผงเพชรเหลว
Compounds



ชุดตะไบเพชรแบบสลับเปลี่ยน
Diamond tip files



หินขัดซูเปอร์สโตน
Super stones



ผงเพชร
Micron lapping powder



ตะไบเพชรหัวโค้ง (BF 90)
Diamond bent Files



หินขัดน้ำมัน
EDM oilpolishing stone

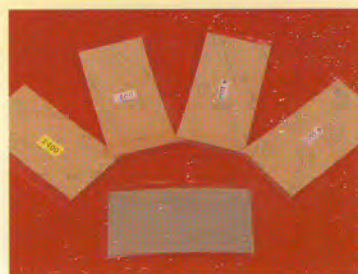

กระดาษทรายเพชร
Diamond Foils



ตะไบเพชร
Files

Camtec

DIAMOND & CBN TOOLS

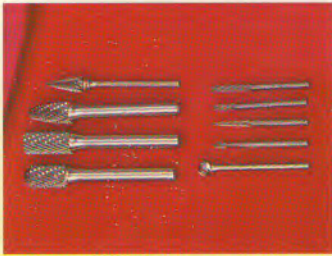

ชุดหัวเจียรคาร์ไบด์ แกน 3.6 มม.
Solid carbide

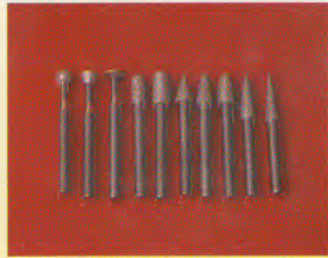

หัวเจียรเพชร (BC-80)
Diamond Mounted wheels



หัวเจียรเพชรแกน 3 มม.(BMS-20)
Diamond mounted point



หัวเจียรรูในเพชร
Internal grinding wheel

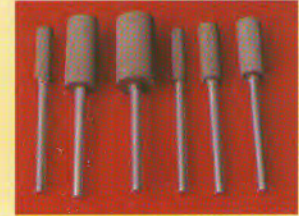

หัวขัดยาง
Elastic mounted point

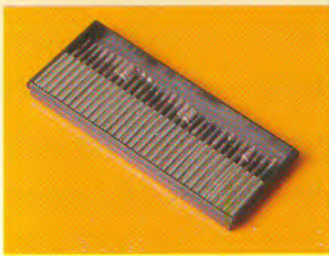

หัวเจียรเพชรแกน 3 มม.
Diamond mounted point BMS-30



หัวเจียรลูกถ้วย
Abrasive cup wheel



หัวเจียรแกน 3 มม. 6 มม.
Abrasive mounted point

Cosmic



เครื่องขัดอัลตราซาวด์ 40 วัตต์
Ultrasonic lapping machine (40 watt)



เครื่องขัดอัลตราซาวด์ 45 วัตต์
Ultrasonic lapping machine (45 watt)



เครื่องเจียรลม
Air grinders



เครื่องเจียรลม
Air grinder (GP-380)



เครื่องเจียรลม
Air grinder (GP-522)

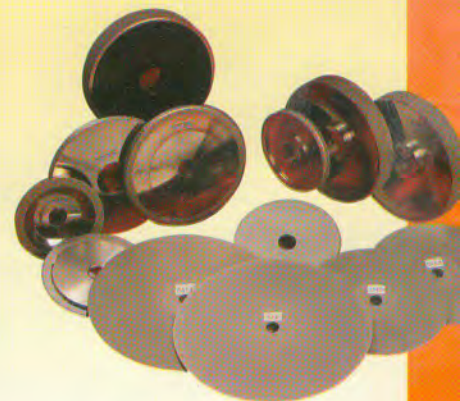

鑽石與氮化硼砂輪
DIAMOND & CBN GRINDING WHEELS

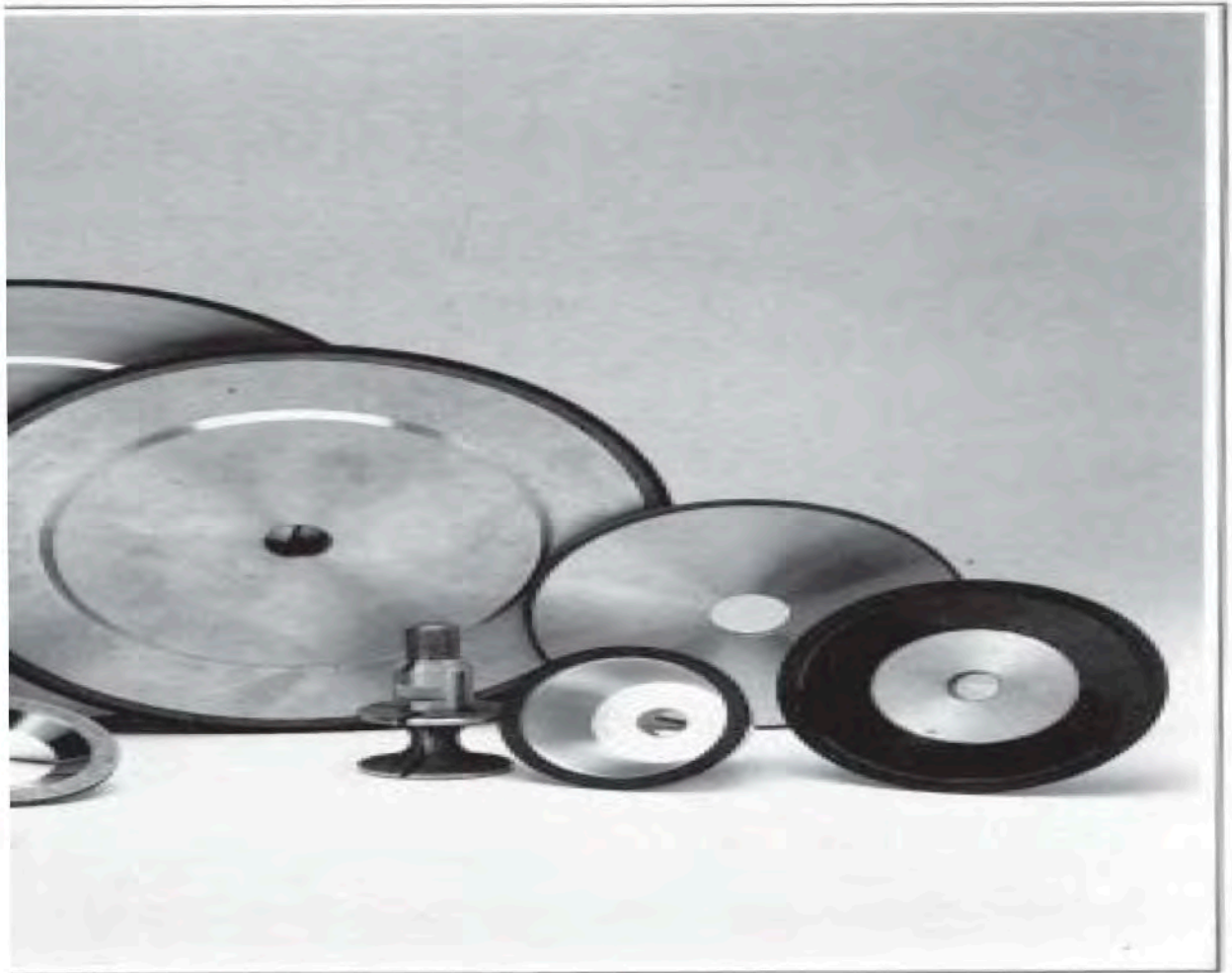

鑽石與氮化硼

鑽石是目前人類所發現最硬的一種磨料。由於它超群的硬度及耐磨耗性，已被廣泛地運用於各種堅硬的非鐵材料之研磨加工。

立方體氮化硼(以下簡稱CBN)是一種介乎傳統磨料與鑽石之間的另一種磨料。CBN對於那些硬淬後難以研磨之鋼材，當傳統砂輪無法滿足加工的需求時，它却發揮了有效且經濟的研磨性能。

適合加工之材質及工件

* 鑽石

- 碳化鎢，半燒結碳化鎢工具及另件
- 陶瓷工具及另件
- 氧化鐵等之磁性材料
- 耐火材料及其製品
- 石材、寶石及半寶石、貝殼
- 玻璃、石英、磁器
- 矽、鍺等電子另件
- 碳、石墨及其製品
- 磁磚、瀝青、混凝土、石棉
- 塑膠、加強塑料(F.R.P.)

* 氮化硼

- SK, SKS, SKH等切削工具或另件
- SKD, Stellite等耐磨工具鋼材
- SCM, SNCM, SCr, SUJ等構造用鋼
- SUS(不銹鋼)等之耐蝕金屬
- SUH, 鈦合金等之耐熱金屬
- 鑄鐵

DIAMOND and CBN

The DIAMOND, which can be considered the hardest abrasive available at present, due to its outstanding hardness and wear resistance, it has been used widely in grinding nonferrous materials, especially, in some hard and dense materials.

CUBIC BORON NITRIDE (CBN) is an abrasive which bridges the gap between conventional abrasives and the diamond. It is excellently for grinding the hard-to-grind ferrous materials where aluminum oxide or silicon carbide wheels fail to perform satisfactorily.

Materials and Workpieces Suitable for Machining:

* With DIAMOND

- Tungsten carbide, presintered carbide metal tools & construction units.
- Oxide ceramic materials
- Ferrite, ceramic magnetic materials
- Refractory products
- Stones, gem & semi-precious stones
- Glass, porcelain, quartz
- Silicon, germanium
- Graphite, carbon
- Tiles, asbestos, asphalt, concrete
- Plastics, F.R.P.
- Wear resistant coatings

* With CBN

- High alloy steels
- High speed tool steels
- Hot & cold working steels
- Tempering steels
- Ball bearing steels
- Spring steels
- Cast iron

如何選購鑽石與氮化硼砂輪

1. 砂輪形狀：

在第8,9頁，我們列出一些主要的砂輪標準形狀，供您在選購時的參考。

對於砂輪形狀的選擇，我們的建議是：在允許的條件下，儘可能採用剛性較佳的砂輪形狀。例如：在條件允許下，儘可能使用6A2型砂輪代替使用11A2型。同理，一個11A2型的砂輪比12A2型的砂輪有較好的剛性。

2. 砂輪外徑：

決定一個砂輪外徑的大小，應依據使用機器的主軸轉速，以能達到建議的砂輪周速度為主要因素。

較大的砂輪外徑，可使磨料有充份的散熱時間及較低的磨耗，所以在允許條件下，儘可能採用較大的砂輪外徑。

3. 砂輪的磨料幅寬 (W)

砂輪的磨料幅寬取決於工件須研磨的面積及使用機器的剛性等。

正確的砂輪使用，應使整個磨料幅寬都被均勻的使用。在機器研磨時，這個要求由工件或砂輪的往覆移動來達到。

對於碗形或碟形砂輪，使用較窄的磨料幅寬，可有較快且較低研磨熱的研磨加工。反之，太大的磨料幅寬將會增加研磨壓力，而導致產生太高的研磨熱及較高的砂輪磨耗。

在徒手研磨時，較大的磨料幅寬，却有導正工作物的效果，使研磨作業容易些。(如車刀的再研磨)

HOW TO SELECT A DIAMOND & CBN WHEEL

WHEEL SHAPE:

On page 8,9 offers a wide range of standard wheel shape for your ordering reference.

In general, we recommended to choose a wheel with better rigid shape; i.e. prefer to select a 6A2 straight cup wheel if the conditions allow instead of using an 11A2 flared cup wheel. Similarly, an 11A2 wheel has better rigidity than a 12A2 wheel.

WHEEL DIAMETER:

Determining the diameter depends mainly on observing the recommended peripheral speeds of wheel.

Larger diameter wheel provide better thermic are kinematic conditions. Hance, it is always recommended to use a wheel its diameter as large as possible.

RIM WIDTH (W):

The rim width of a wheel is to be determined with size of workpiece area to be ground. and the rigidity of the machine, etc.

A correct grinding operation is the entire rim width of wheel should be used uniformly. In machanical grinding, this is achieved by the feed movement of the workpiece or the grinding wheel.

In cup and dish grinding, narrow rim width perform quicker and cooler grinding, on the contrary, too wide contact areas cause higher grinding force and result in more grinding heat and higher wheel wear.

In off-hand grinding, however, a larger rim width car be beneficial as it makes quidance of the workpieed easier.

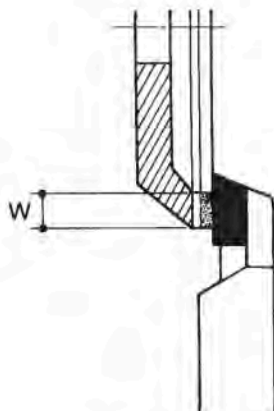

機械研磨
Mechanical Grinding

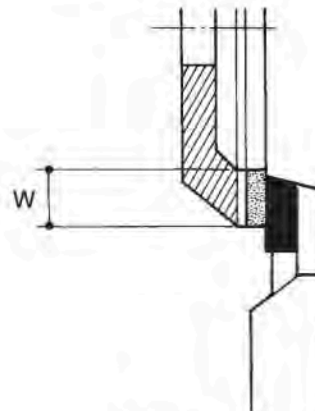

徒手研磨
Off-hand Grinding

4. 磨料層厚度：

對砂輪的製造而言，不論它的磨料層厚度是大或小，其製造成本都是一樣的。因此，除非砂輪的使用頻率很低或特殊用途，否則應該選擇較大的磨料層厚度，因為對使用者而言，那是較經濟的。

5. 粒度：

粒度決定一個砂輪的研磨量及可獲致的工件表面加工粗度。一般而言，在允許的表面加工粗度範圍內，應採用最大的粒度，以使砂輪能有最佳的研磨量。

鑽石與CBN砂輪的粒度範圍，有下列兩種：

- a) 篩目粒度
- b) 微粉粒度

RIM THICKNESS:

Larger rim thickness are more economical, because even the different rim thickness have the same manufacturing cost for a wheel. This results in an advantage for the user to get lower grinding cost.

GRIT SIZE:

The grit size of a wheel determines the stock removal capacity and surface finish of the workpiece that can be attained.

For best stock removal capacity, it is general of advantage to use the largest grit size allowing surface quality request.

There are two ranges of grit size:

- a) Sieve grains
- b) Micron grains

1) 篩目粒度 / Sieve grains

稱呼粒度 Nominal grit size (mesh)	美國標準 US Standard (mesh per inch)	歐洲標準 FEPA Standard Sieve grit size	國際標準粒徑 ISO Mesh Widths (μm)
#30	#30/40	D602	600/425
#40	#40/50	D427	425/300
#50	#50/60	D301	300/250
#60	#60/80	D252	250/180
#80	#80/100	D181	180/150
#100	#100/120	D151	150/125
#120	#120/140	D126	125/106
#140	#140/170	D107	106/90
#170	#170/200	D91	90/75
#200	#200/230	D76	75/63
#230	#230/270	D64	63/53
#270	#270/325	D54	53/45
#325	#325/400	D46	45/38

2) 微粉粒度 / Micron grains

大約網目尺寸 Approx. mesh size	#400	#500	#600	#800	#1000	#1200	#1800	#3000
粒徑範圍 Micron range (μm)	40-60	36-54	30-40	20-30	15-25	10-20	6-12	4-8

鑽石與氮化硼砂輪之加工參數

Machine parameters of diamond and CBN wheels

* 平面研磨 / Surface grinding:

進刀量 / infeed:

#80 - #120	0.01 - 0.04mm
#140 - #200	0.01 - 0.02mm
#230 - #325	0.005 - 0.01mm

橫向進給速度 / table speed: 10-25m/min.

縱向進給速度 / cross speed:

for diamond: 1/5-1/3 of rim width.

鑽石砂輪: 砂輪磨料層幅寬之1/5~1/3。

for CBN: 1/4-3/4 of rim width.

CBN砂輪: 砂輪磨料層幅寬之1/4~3/4。

* 內孔研磨 / Internal grinding:

進刀量 / infeed:

#80 - #120	0.005 - 0.02mm
#120 - #200	0.002 - 0.01mm
#230 - #325	0.001 - 0.007mm

橫向進給速度 / table speed: 0.5-2m/min.

工件周速度 / peripheral speed of workpiece:
20 ~ 40m/min.

* 外徑研磨 / External cylindrical grinding:

進刀量 / infeed:

#80 - #120	0.01 - 0.03mm
#140 - #200	0.01 - 0.02mm
#230 - #325	0.005 - 0.01mm

橫向進給速度 / table speed: 0.5-2m/min.

工件周速度 / peripheral speed of workpiece:
20 ~ 40m/min.

* 工具研磨 / Tool grinding:

進刀量 / infeed:

#80 - #120	0.02 - 0.05mm
#120 - #200	0.01 - 0.03mm
#230 - #325	0.005 - 0.01mm

橫向進給速度 / table speed: 0.5-4m/min.

* 以上提供的加工參數，可視為一種參考數據，在實際的運用上，仍需根據機械剛性，工件特性及尺寸，砂輪外徑，砂輪磨料層幅寬等條件加以修正。但有一個基本原則是可遵循的：

若用高進給速度，則宜採較小進刀量；

若用低進給速度，則可採較大進刀量。

* 深進刀研磨

由於深進刀研磨較一般研磨有經濟性的優勢，所以愈來愈受到重視，基本上，這種研磨均採用濕式研磨，且均採高進刀量及低橫向進刀速度。

採用深進刀研磨，機械的要求就要特別嚴格，例如高強度的機械剛性及緩慢的橫送驅動裝置。

這種研磨技術，由於廣泛的運用條件，實在很難提供一個正確的加工參數，在此，我們僅提供一個一般性的技術參數範圍供參考：

進刀量：0.1~1.5mm / 次

橫向進刀速度：10~300mm / min

* Above parameters table should only be considered as a reference datas. On actual operation, depend on machine rigidity, workpiece size and properties, wheel diameter and rim width to modify these values.

In generally, please follow the rule:

High table speed with low infeed and low table speed with high infeed.

* Deep grinding

Compare to swing-frame grinding, because of its greater chip removal, the deep grinding performs its economical surperiority and becomes more and more important. Its character is performed by high infeed and low table speed, and is performed with sufficient wet grinding only. The machines therefore should have stronger rigidity, creep table feed driving device and sufficient coolant supplier.

Owing to the wide variety of applications, this process is difficulty to specify exact machine parameters. In general machine parameters should be within the following ranges:

Infeed: 0.1-1.5 mm/pass

Table speed: 10-300 mm/min.

用游離磨粒來修整碗形砂輪

碗形砂輪可以用游離磨粒來修整磨料層之平面度及修銳。將#80~#140之GC磨料散放於玻璃板或鑄鐵平板上，用手拿著砂輪以畫8字形方式輕輕地修整平面度及修銳。

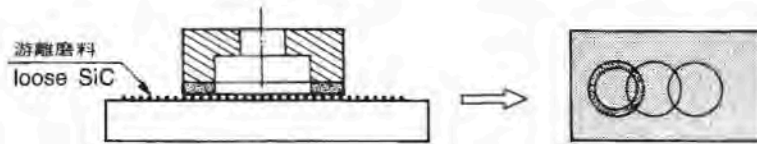

Truing and dressing with loose SiC

Poured SiC grain of grit size #80 to #140 on the plane surface of a glass or cast iron plate, and the diamond or CBN wheels is moved over the grain with light pressure. Like this to achieve good planeness on face rims of a cup wheels.

用GC油石條來修銳砂輪

鑽石或CBN砂輪，如採用(1)或(3)方式修整後，一定要用#220的GC油石條再做修銳的處理，如此，砂輪方有良好的研磨性能。此外，當鑽石或CBN砂輪經研磨後，若發生塞目或感覺不銳利時，用GC油石條來清除塞目使新研磨刃重現，也是十分有效的方法。此方法可適用於平直型或碗形砂輪，其進削量為1~3mm，橫送速度為1~3M/min，如此反覆修銳至完成為止。有一點應注意的是砂輪轉速應降低，若轉速固定，則採取時開時關電源之方法，利用油石條之減速作用達到修銳目的。

Dressing wheel rim with dressing sticks

After the geometrical shaping, the truing of the diamond and CBN wheels by method of 1 and 3, it is necessary to dress these wheels by using a dressing sticks to sharpen the wheel rim. It can also help to overcome clogging problems when the wheel has been used under wrong conditions.

A GC dressing sticks with grit size #220 and infeed 1-3 mm, feed speed 1-3 m/min, is applied. The dressing sticks must be pressed hard against the grinding wheels. This is normally operated by hand, but a suitable device may also be used.

Anyway, please use lower spindle speed, when dressing operations.

砂輪的周速度

周速度對於砂輪的研磨性能，砂輪壽命及工件的加工表面粗度有很大的影響，因此我們鄭重地建議您：一定要依據機械的主軸轉速，選擇適當的砂輪外徑，以使能夠達到合適的砂輪周速度。

以下是我們建議的砂輪周速度：

Wheel peripheral speed

Wheel life performance and machined surface quality depend largely on the peripheral speed of the wheels. Hence we recommend to select wheel diameter and spindle speed in accordance with the correct wheel peripheral speed.

For the recommended peripheral speed, see the table below:

	鑽石砂輪 / for diamond wheels	CBN砂輪 / for CBN wheels
樹脂砂輪 / Resin bond:		
濕磨 / Wet grinding	1400-1800 m/min.	1500-2100 m/min.
乾磨 / Dry grinding	750-1200 m/min.	1000-1500 m/min.
金屬砂輪 / Metal bond:		
濕磨 / Wet grinding	1400-1800 m/min.	1500-2100 m/min.
乾磨 / Dry grinding	500-1000 m/min.	500-1200 m/min.
電鍍砂輪 / Electroplated bond:		
乾、濕磨 / Wet & dry grinding	600-1800 m/min.	600-1800 m/min.

訂製砂輪時，請告知事項：

1. 砂輪的形狀及各部尺寸：
請參考第 8 頁所列的砂輪形狀，告知所須砂輪之形狀及各部尺寸。若有特殊形狀之砂輪，請提供圖面訂製。
2. 磨料的種類：鑽石或 CBN？
3. 粒度：請參考第 4 頁之粒度表。
4. 磨料集中度：見第 5 頁。
5. 結合劑：電鍍法、樹脂法或金屬法？
6. 冷卻方式：乾磨或濕磨？
7. 數量及要求交貨期：
8. 其他告知事項：
 - a) 以上為訂製砂輪之必需資料，請您務必詳細逐一告知。
 - b) 若能再提供以下更詳細資料，將有助於我們為您製作更適合的砂輪：
 - 1) 工件名稱，材質，硬度。
 - 2) 機器名稱，型式及馬力。
 - 3) 加工條件及加工精度。
 - c) 若是重覆訂製，請告知刻於砂輪上之製造號碼即可。但對原砂輪若有任何不滿意之處，請告知缺點供我們改進。

* When ordering, please specify:

1. Shape & dimensions of wheels:
Please refer to page 8, specify the shape & dimensions of wheel. and please furnish with print or sketch on all special requirement.
2. Kind of abrasive: Diamond or CBN?
3. Grit size: Refer to page 4.
4. Concentration: Refer to page 7.
5. Bond of wheels:
6. Coolant: Dry or wet grinding?
7. Quantity & delivery:
8. Other informations:
 - a) Above informations are basic conditions to order a wheel.
 - b) Please inform more details as follow to help us to make a better tools for you:
 - 1) Name, materials, hardness of workpiece.
 - 2) Name, type, horse power of machine.
 - 3) Grinding conditions.
 - c) When repeat order, please just tell us the manufacturing no., but if you didn't satisfy with the quality of the last wheels, please let's know the details, then we can improve it.

輪之標示方法 / Nomenclature for Grinding Wheels:

S D C 磨料種類 Kind of abrasive	2 0 0 粒 度 Grit size	N 結合度 Grade	7 集 中 度 Concentration	R 結 合 劑 Bond	3 . 0 磨料層厚度 Rim thickness
鑽石 / DIAMOND: D: 天然 Natural SD: 人造 Synthetic SDC: 人造金屬披覆 Synthetic metal coating	#30 / #3000 see page 4 見第 4 頁	J 軟/soft L N ↓ P R 硬/hard	25 50 75 100 125 150	R: 樹脂 Resin M: 金屬 Metal P: 電鍍 Electro-plated	1.0mm 1.5mm 2.0mm 3.0mm . .
氮化硼 / CBN: B: 氮化硼 CBN BC: 金屬披覆 Metal coating					

砂輪形狀及尺寸標示 / Shape & Dimension of Wheels

1A1

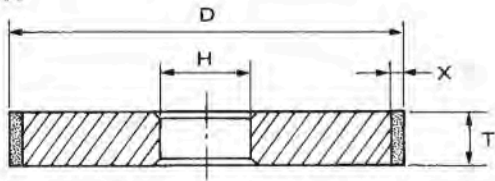

3A1

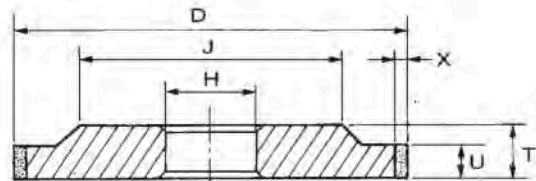

14A1

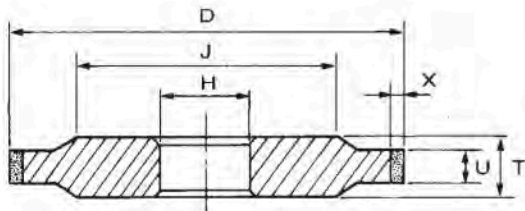

6A2

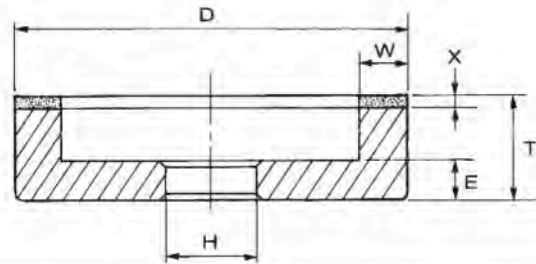

11A2

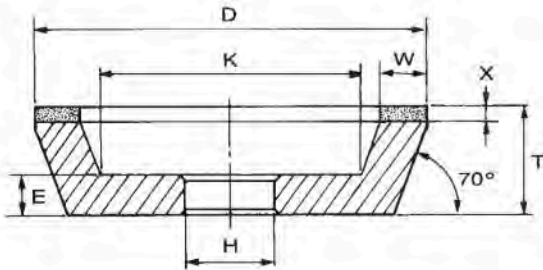

11B2

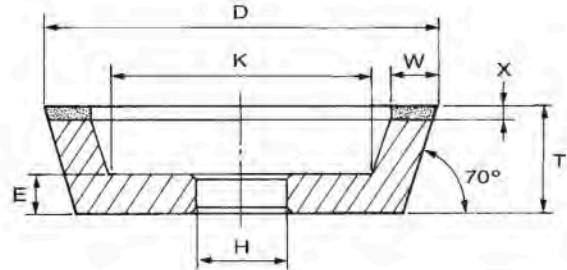

12B2

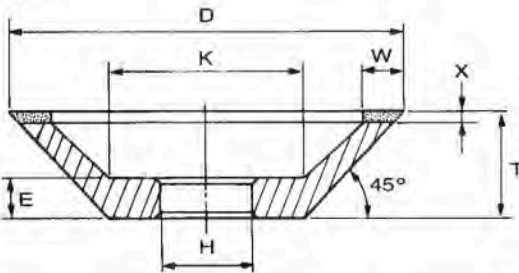

11C9

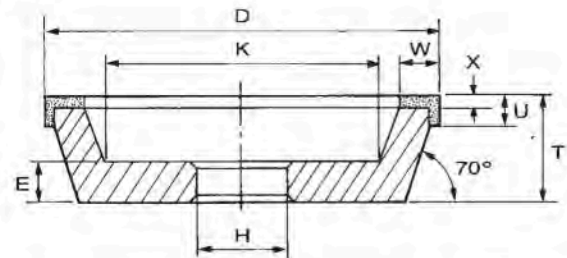

11Y9

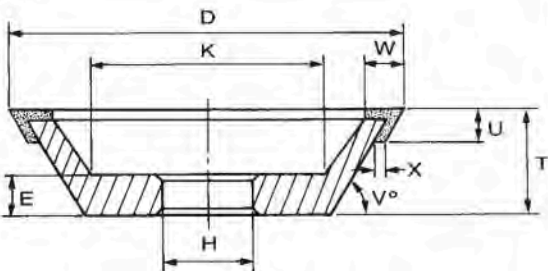

6A9

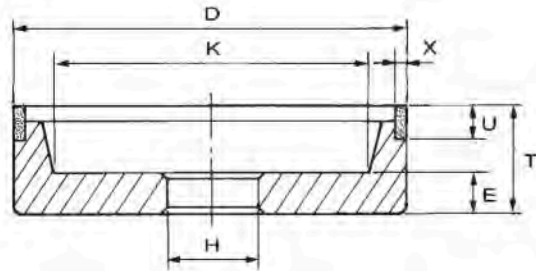

1FF1

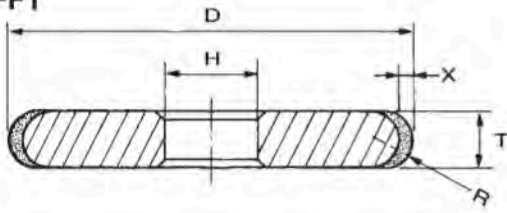

1L1

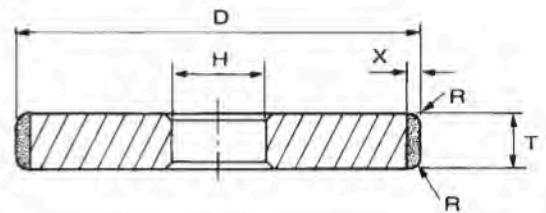

11V9

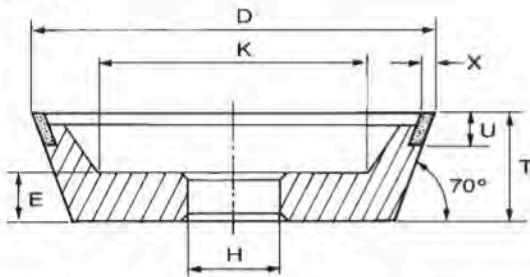

12V9

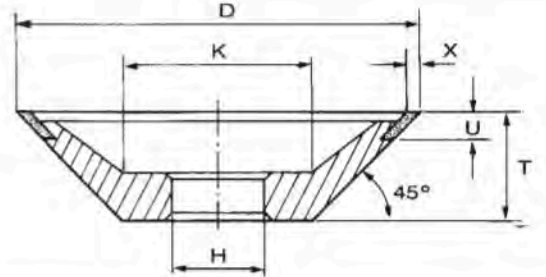

1EE1

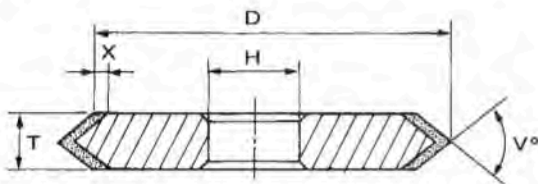

1V1

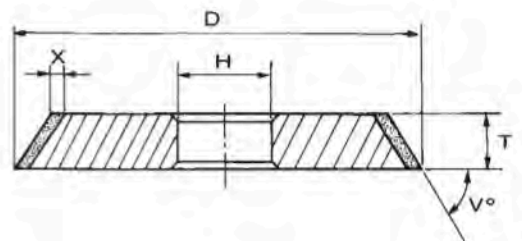

12A2

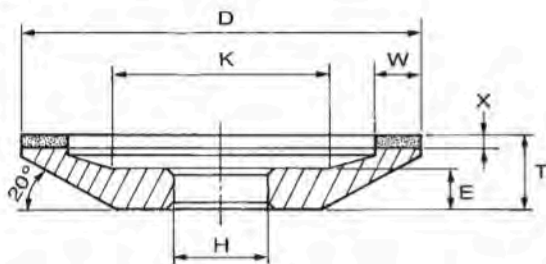

4A2

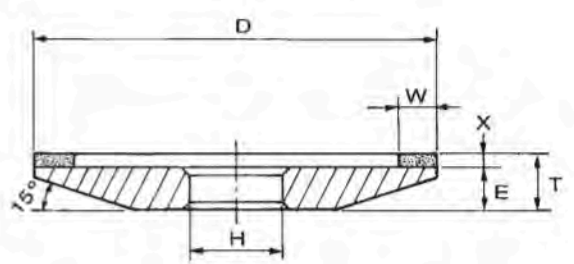

9A3

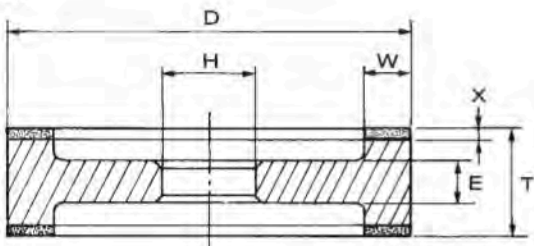

14U1

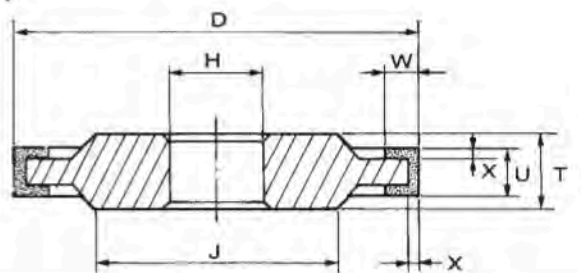

鑽石修刀

DIAMOND DRESSING TOOLS

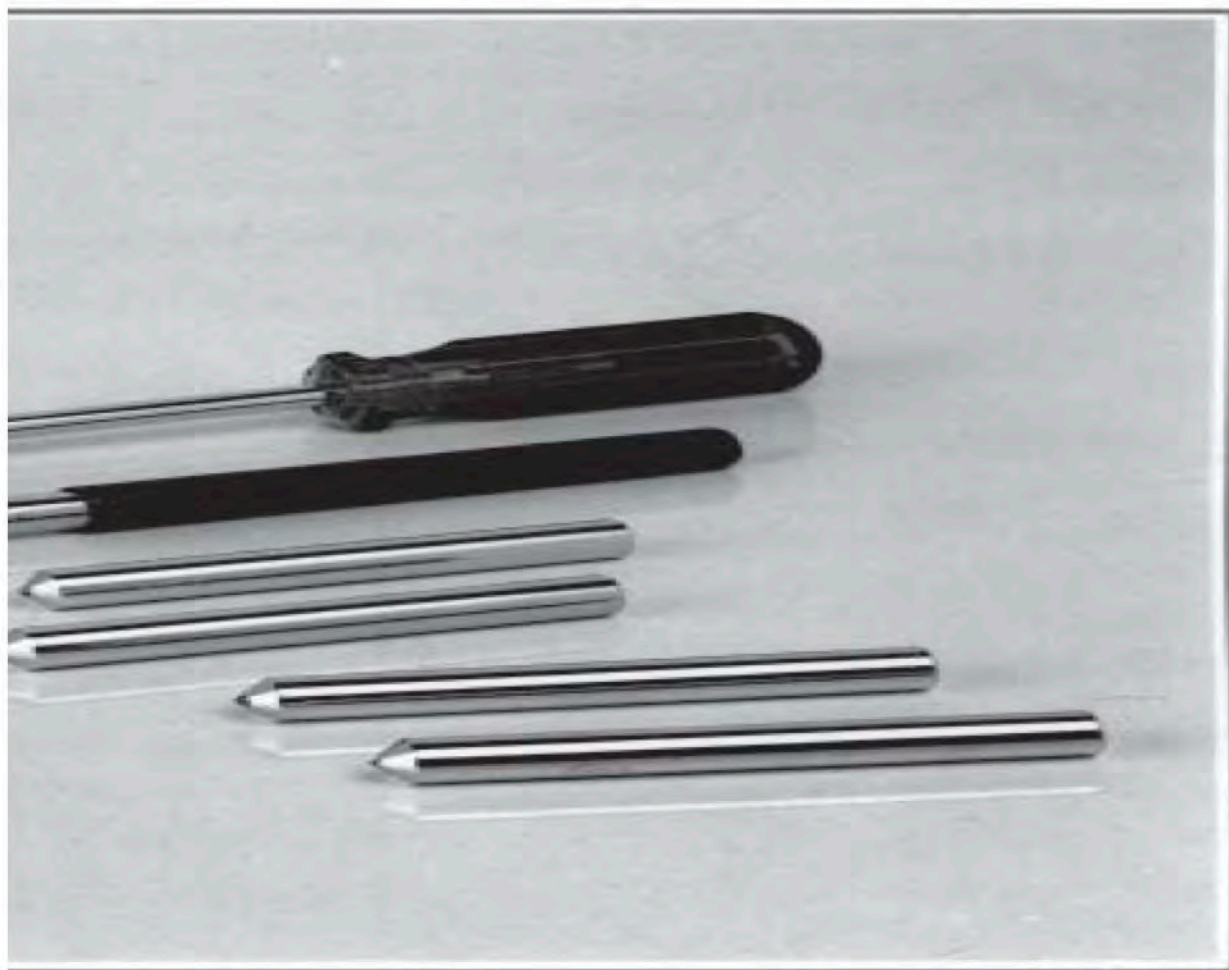

單石修刀 Single Point Diamond Dressers



● 鑽石品質分類

修刀的鑽石品質，包含兩個主要因素：結晶好壞及可供使用的刃角數（結晶形狀）。品質越好的原石，結晶強韌、耐磨耗，且可以多次翻修。因此，它提供良好的修整效果及更長的工具壽命。所以一味追求低價位的修刀，並非是最經濟的選擇。

● Diamond Quality

GRADE A: A very good quality toolroom stone with 4-6 points good shape and free of inclusions or cracks. Sizes available 0.10 carat to 2.0 carat.

GRADE B: A general toolroom quality of good shape with 2-3 working points. Sizes available 0.10 carat to 2.0 carats.

GRADE C: Standard quality with 1 or 2 points and of irregular shape. Sizes available 0.20 carat to 2.0 carats.

鑽石番號 Dia. wt. code	大約重量 (克拉) Approx. wt. (cts.)	精選級 Grade A	標準級 Grade B	經濟級 Grade C	適用砂輪 Grinding wheels size (mm)
#2	0.10 cts.	DS002A	DS002	—	φ150×25 以下 or smaller
#3	0.12	DS003A	DS003	—	
#4	0.15	DS004A	DS004	—	
#5	0.18	DS005A	DS005	—	
#10	0.20	DS010A	DS010	DS010C	
#15	0.25	DS015A	DS015	DS015C	φ150 ~ φ300×25
#20	0.35	DS020A	DS020	DS020C	
#25	0.50	DS025A	DS025	DS025C	
#33	0.75	DS033A	DS033	DS033C	
#50	1.0	DS050A	DS050	DS050C	φ300 ~ φ450×25 - 40
#75	1.5	DS075A	DS075	DS075C	φ450 ~ φ600×50 - 100
#100	2.0	DS100A	DS100	DS100C	φ600 以上 / or larger.

† 精品之鑽石等級為標準級，其他等級請指明訂購。

Grade B is standard grade, and grade A & C depend on your requirement.

* 如何訂購

敬請指明：

- 1) 鑽石番號
- 2) 鑽石品質
- 3) 鐵柄形狀
- 4) 鐵柄尺寸

* How to order

Please specify:

- 1) Diamond weight
- 2) Diamond quality
- 3) Type of shank
- 4) Size of shank

* 加工參數 / Machine parameters

- a) 精密研磨 / for precision grinding: 0.005mm/pass.
- b) 一般研磨 / for general grinding: 0.01—0.03mm/pass.
- c) 銳利研磨 / for removal grinding: 0.05mm/pass.

● 正確安裝及使用 / Installation and operation

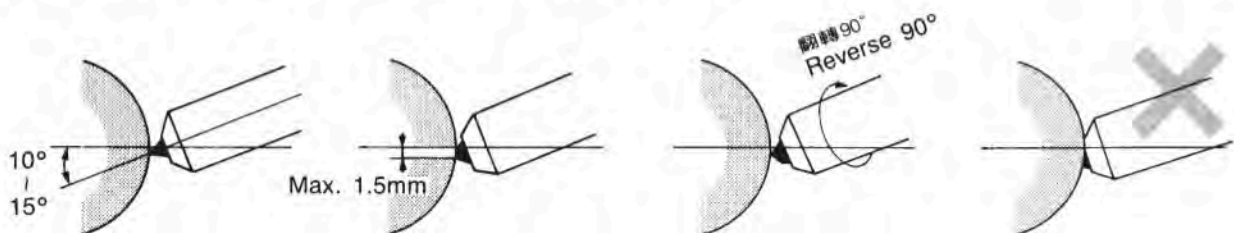

●鐵柄形狀及尺寸 / Shape and size of shank

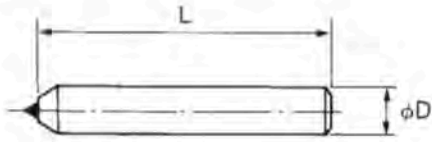

φD	6	8	8	8	10	11	12	12
L	30	30	50	100	80	50	50	100

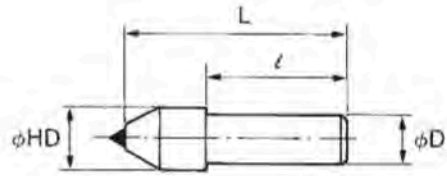

φD	φHD	L	l
3	4	20	12
6	12	27	12
6	12	35	20
6.35	12.7	32	12.7
8	12	26	16
8	12	35	20
11	16	35	20

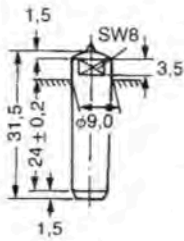

MT#0

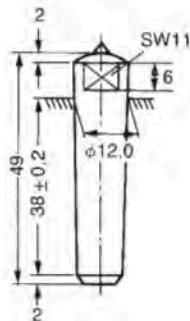

MT#1

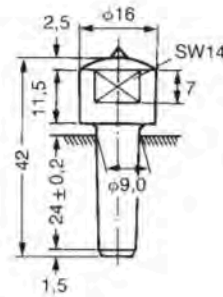

MT#0

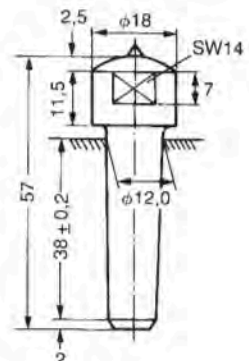

MT#1

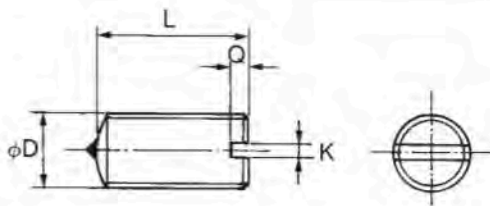

φD	L	K	φ
M8×1	16	1.0	2
M8×1.25	40	1.5	2
M12×1.5	40	1.5	2

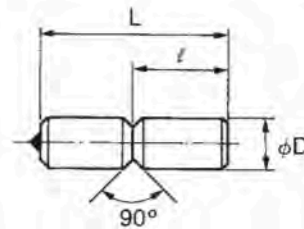

φD	L	l
6	8	4
10	16	7
10	20	9
11	35	16
11	40	20

〈註〉除以上規格尺寸外，其他規格請指明訂購。

Please furnish with print or sketch on all special requirement.

結合修刀

Impregnated Diamond Dressers

特長：

1. 品質穩定，壽命長，具經濟性。
2. 修刀本身具自銳性，使用時不需翻轉修刀，可長時間使用。
3. 因鑽石面大，因此可快速地達到修整的效果。

FEATURES:

1. The quality is steady and have longer tool life.
2. It is a self-sharpening tools, no need to reset or reverse the tools during dressing.
3. Dressing can be accomplished quickly, because of the large diamond section.



編號 Order No.	鑽石部份尺寸 Diamond Section Size	粒度 Grit Size	鐵柄形狀 Type Of Shank	鐵柄尺寸 Size Of Shank	適用範圍 Applications
DI-1AMA	1A 	M	A.	$\phi 12 \times 50$ $\phi 11 \times 30$	無心研磨、圓筒研磨、平面研磨， 砂輪尺寸在 $\phi 500 \times 75$ 或以上 For centreless, cylindrical surface grinding. wheel size: $\phi 500 \times 75$ and larger.
DI-1ARA		R			
DI-1AMB		M	B.	$\phi 12 \times 50$ $\phi 11 \times 30$	
DI-1ARB		R			
DI-2AFC	2A 	F	C.	$\phi 12 \times 100$ $\phi 12 \times 50$ $\phi 11 \times 30$	無心研磨、圓筒研磨、平面研磨， 砂輪尺寸 $\phi 300 \times 25$ 到 $\phi 500 \times 63$ For centreless, cylindrical, surface grinding. wheel size: $\phi 300 \times 25$ to $\phi 500 \times 63$
DI-2AMC		M			
DI-2ARC		R			
DI-2AFD		F	D.	$\phi 12 \times 50$ $\phi 11 \times 30$	
DI-2AMD		M			
DI-2ARD		R			
DI-3AFE	3A 	F	E.	$\phi 12 \times 50$ $\phi 11 \times 30$	一般用途之研磨，砂輪尺寸在 $\phi 300 \times 25$ 到 $\phi 500 \times 13$ For general purpose grinding. wheel size: $\phi 300 \times 25$ to $\phi 500 \times 13$
DI-3AME		M			
DI-1CFG	1C 	F	G.	$\phi 12 \times 50$ $\phi 11 \times 30$	一般用途之研磨，砂輪尺寸在 $\phi 350$ 或以下 For general purpose grinding wheel size: $\phi 350$ and smaller.
DI-1CMG		M			
DI-1CRG		R			
DI-2CFG	2C 	F	G.	$\phi 12 \times 100$ $\phi 12 \times 50$ $\phi 11 \times 30$	一般工具研磨用，砂輪尺寸在 $\phi 250$ 或以下 For general operations on tool-room grinders. Wheel size: $\phi 250$ and smaller
DI-2CMG		M			

註：鑽石粒度與砂輪粒度

粗目 (R)：使用於 # 46 或更粗的砂輪修整。

中目 (M)：使用於 # 54 ~ # 100 的砂輪修整。

細目 (F)：使用於 # 120 或更細的砂輪修整。

Remark: Diamond Grit Size

Coarse (R): for wheel grit size #46 or coarser

Medium (M): for wheel grit size #54-#100

Fine (F): for wheel grit size #120 or finer.

多石修刀 Multipoint Diamond Dressers







特長：

1. 由數顆較小較便宜的鑽石，代替較大較貴的單石修刀，可降低工具成本。
2. 修刀的負荷由多顆鑽石分擔，磨耗低且均勻，又不易過熱。

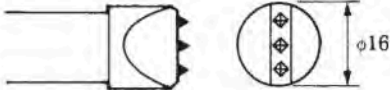
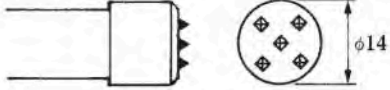
FEATURES:

1. Because smaller stones cost less per carat than a big one, so use a multipoint dressers to replace a large single point dressers can reduce tool cost.
2. The burden of impact on tools is distributed over several points, they therefore wear more slowly and evenly, and seldom chip, burn or fail until they are used up.

編號 Order No.		總鑽石重量 Total Dia. Wt.	鑽石顆數 Nos. of Dia.	鑽石層數 Nos. of layer
DM03201		1.0 ct.	3	1
DM05101		1.0 ct.	5	1
DM06101		1.0 ct.	6	1
DM07101		1.4 ct.	7	1
DM03101		0.6 ct.	3	1

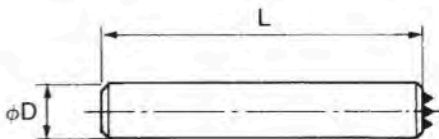

ϕD	9.53	11	11	12	12
L	50	50	100	50	100

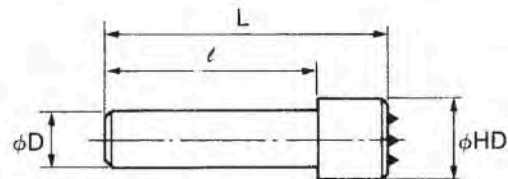

ϕHD	20	20	16	16	14	14
ϕD	12	12	12	12	12	12
L	50	100	50	100	50	100
l	35	85	35	85	35	85



成型修刀 Forming Diamond Dressers

成型修刀用於砂輪之成形修整，或內、外弧之成形修整。
For forming accurate radii and forms on grinding wheels.

■ 斧鑿型 (Chisel Type)

編號 Order No.	鑽石角度 Included angle on diamond	鑽石端弧度 Radius on diamond end	鑽石原料 Diamond material
DF0255 DF0560	55° 60°	0.2 0.5	天然鑽石 Natural diamond
DF0245F DF0255F DF0560F	45° 55° 60°	0.2 0.2 0.5	人造鑽石 Synthetic diamond

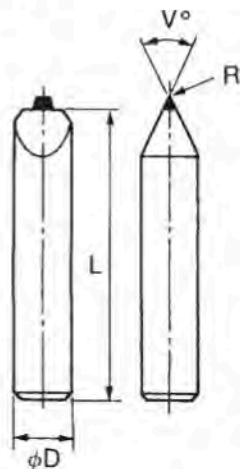
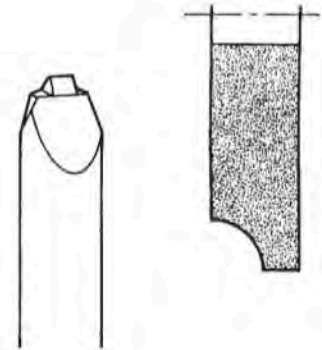

phi D	L
10	80
12	80

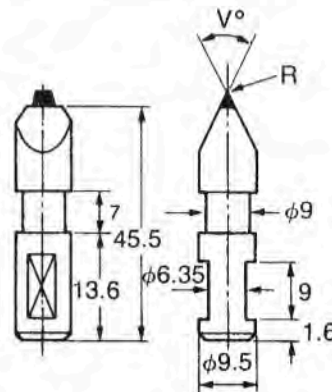

說明：

1. 鑽石角度 (V) 及弧度 (R) 由客戶指定。
2. 其他鐵柄形狀及尺寸，敬請指明訂購。

Remark:

1. V & R depend on requested.
2. Other specifications depend on your requirement.

■ 圓錐型 (Cone Type)

編號 Order no.	鑽石角度 Included angle on diamond	鑽石尖弧度 Radius on diamond end	鐵柄尺寸 Shank size
DC601	60°	0.02—0.03	phi 1/8" x 2"
DC602	60°	0.02—0.03	phi 1/4" x 2"
DC603	60°	0.02—0.03	phi 3/8" x 2"
DC604	60°	0.02—0.03	phi 10mm x 50mm

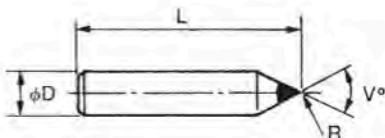
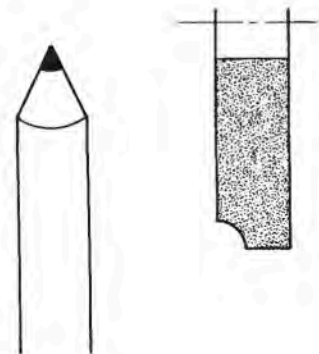

phi D	1/8"	1/4"	3/8"	10mm
L	2"	2"	2"	50mm



手持式鑽石修刀 Hand Diamond Dressers

特長：

1. 易於握持，修整砂輪容易。
2. 快速，安全，壽命長，經濟實用。

FEATURES:

1. Tool shank is suitable to handle and easy to dress.
2. Quickly and safely dressing is possible, besides, it is economical.

形式 Form	編號 Order No.	鑽石尺寸 Diamond Size	粒度 Grit Size
Type 01 總長 / Total length: 160mm 	HD-01R HD-01F	 13x6.5x7(mm)	R: 粗目/Coarse F: 細目/Fine
Type 02 總長 / Total length: 200mm 或 OR 方向① Direction ① 方向② Direction ②	HD-02R HD-02F	 20x6x5(mm)	R: 粗目/Coarse F: 細目/Fine



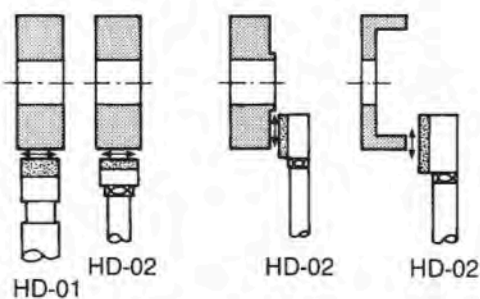



■使用例 (Applications):



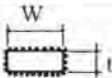
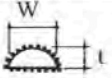

“ベスト”はダイヤモンドの専門メーカーとしてより質の高いさまざまなニーズに応え、まごころのある高品質な製品づくりをめざしています!!

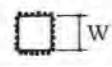

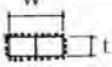
— 記号説明 —

ヤスリの形状 / The Shape of Diamond Files:

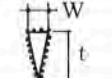
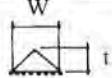
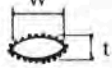
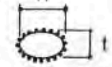
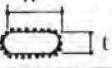
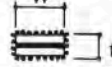
		呼称 Descriptions
	W×t	平 Flat
	W×t	半丸 Half-round
	φd	丸 Round
	W	角 Square
	W	三角 Triangle
	W×t	先細 Warding

		呼称 Descriptions
	W×t	刀刃 Knife
	W×t	蛤 Barrette
	W×t	両半丸 Crossing
	W×t	だ円 Oval
	W×t	平丸 Crochet
	W×t	平, テーパー付 Flat with Taper













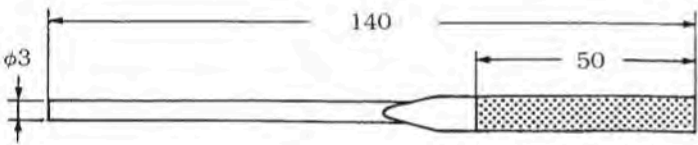







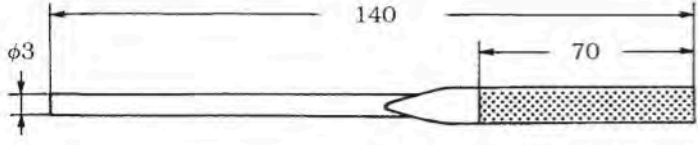

マークの説明 / The Means of Symbols:

- | | | | |
|---|-------------------------------|---|----------------------------------|
| # | : 粒度 / Grit Size |  | : セットと本数 / Set Form & Pcs. / Set |
| #100 | : 標準品の粒度 / Standard Grit Size | No. | : ご注文番号 / Order No. |
| #150 | : 特注品の粒度 / Optional Grit Size |  | : 断面形状 / Shape of Tools |
|  | : 寸法単位 / Unit of Dimension |  | : 寸法 / Dimension |



PF ダイヤモンド精密ヤスリ Diamond Needle Files

 : mm

		No.			¥
1. PF-10 #: (#120), #200, #400 	PF-101		6×1.5	850	
	PF-102		5×2	850	
	PF-103		φ3	850	
	PF-104		2.5	850	
	PF-105		3.5	850	
	PF-106		5.4×1.5	900	
	PF-107		1.7×6	900	
	PF-108		6×2	900	
	PF-109		5×2	900	
	PF-110		6×1.5	900	
	2. PF-10L #: (#120), #200, #400 	PF-101L		6×1.5	1,150
PF-102L			5×2	1,150	
PF-103L			φ3	1,150	
PF-104L			2.5	1,150	
PF-105L			3.5	1,150	
PF-106L			5.4×1.5	1,200	
PF-107L			1.7×6	1,200	
PF-108L			6×2	1,200	
PF-109L			5×2	1,200	
PF-110L			6×1.5	1,200	

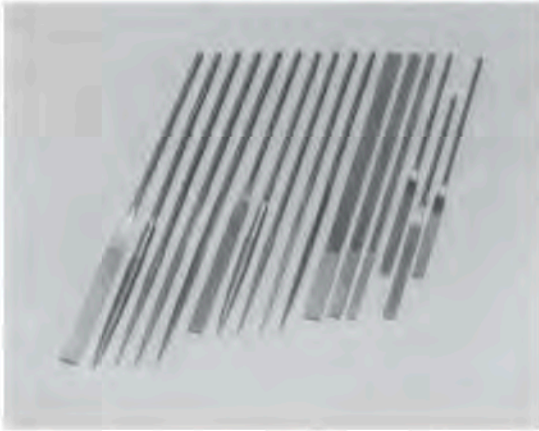

PF ダイヤモンド精密ヤスリ Diamond Needle Files

: mm

		No.			¥
3. PF-20 #: #120, #200 	PF-201		8.5×1.6	2,400	
	PF-202		7×2.5	2,400	
	PF-203		φ4	2,400	
	PF-204		3.5	2,400	
	PF-205		4.5	2,400	
	4. PF-30 #: #120, #200 	PF-301		7.5×1.5	1,800
PF-302			6×2.1	1,800	
PF-303			φ3.5	1,800	
PF-304			3	1,800	
PF-305			4	1,800	

5. PF-70 平薄手タイプ

#: #150, #200, #400

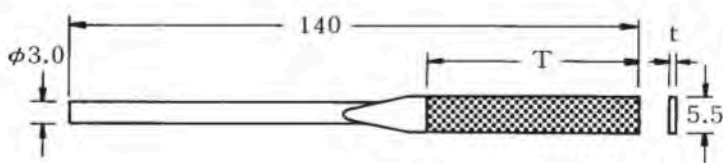

No.	T	t	¥
PF-705	40	0.5	1,000
PF-708	50	0.8	1,000
PF-710	50	1.0	1,000

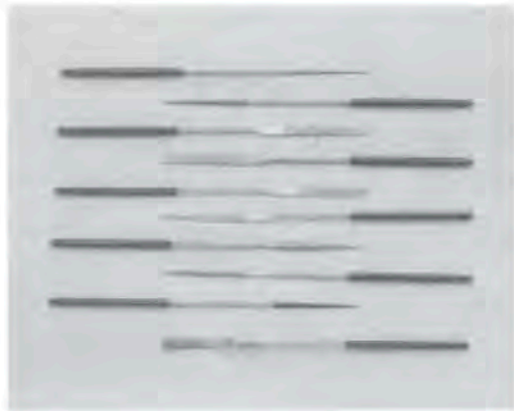

PF

ダイヤモンド精密ヤスリ
Diamond Needle Files



10本セット/10pcs. Set
PFL-10 ¥10,000/Set (木箱ケース入)

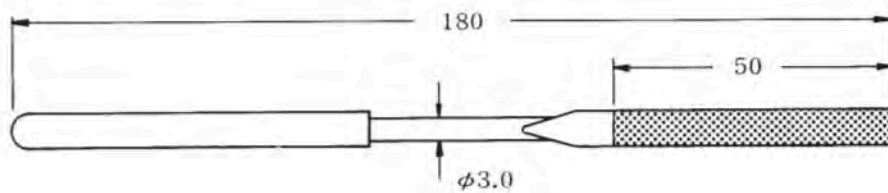

: mm

#: #200	No.			¥
	PFL-101		5.5×1.5	950
	PFL-102		5×2	950
	PFL-103		φ3	950
	PFL-104		2.5	950
	PFL-105		3.5	950
	PFL-106		5.5×1	950
	PFL-705		5.5×0.5	950
	PFL-708		5.5×0.8	950
	PFL-03		φ2	950
	PFL-01		5.5×1.5	950



PTF

ダイヤモンド精密ヤスリ Diamond Needle Files

 10本セット / 10pcs. set
 PTF-10 ¥11,000/set (プラスチック入)
 PTF-10T ¥13,500/set (木箱ケース入)
 (ピンバイス付 / With tool holder)

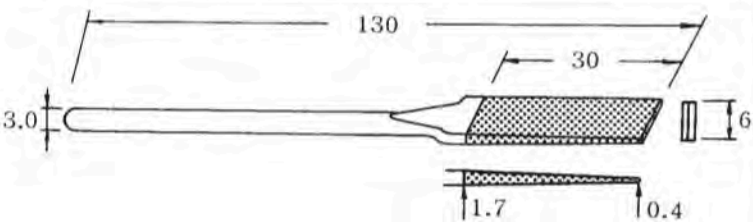
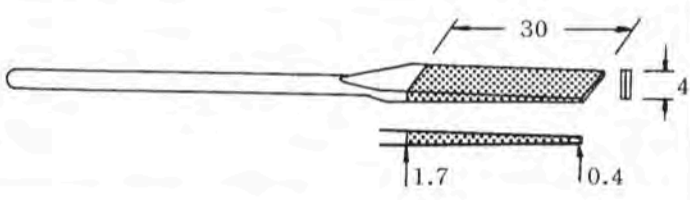
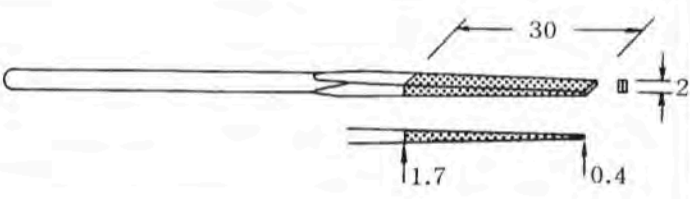
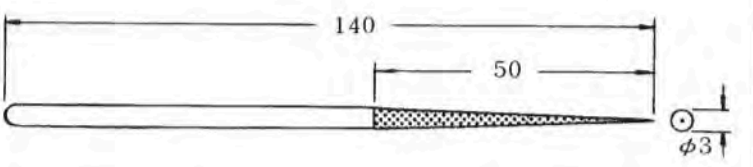
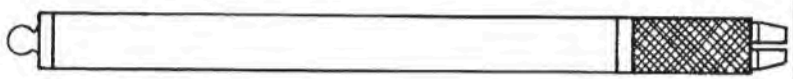
# : #200 #400 #600		mm		
#	No.	#	¥	
	PTF-16F	#200	1,150	
	PTF-16V	#400	1,150	
	PTF-16X	#600	1,150	
	PTF-14F	#200	1,100	
	PTF-14V	#400	1,100	
	PTF-14X	#600	1,100	
	PTF-12F	#200	1,000	
	PTF-12V	#400	1,000	
	PTF-12X	#600	1,000	
	PF-103X	#600	900	
	XH-22		2,300	



BF ダイヤモンドコテヤスリ Diamond Bent Files

: mm

BF-60 タイプ / Type

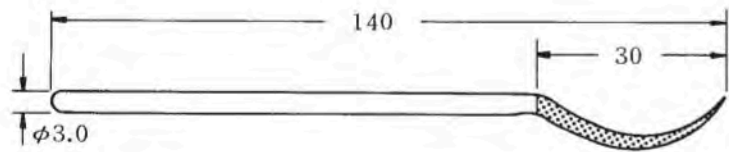

5本セット / 5 pcs. set
BF-600 ¥4,500/set

#: #150	No.			¥
	BF-601		6×1.5	900
	BF-602		5×2	900
	BF-603		φ3	900
	BF-604		2.5	900
	BF-605		3.5	900

BF-90 タイプ / Type

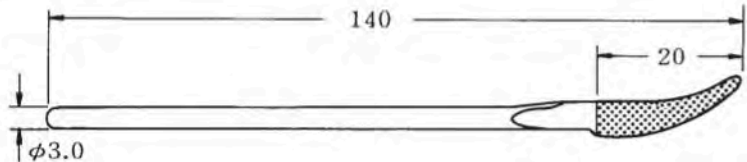

10本セット / 10 pcs. set
BF-900 ¥ 9,000/set

#: #150										
No.	BF-901	BF-902	BF-903	BF-904	BF-905	BF-906	BF-907	BF-908	BF-909	BF-910
¥	900	900	900	900	900	900	900	900	900	900



BF

ダイヤモンド両コテヤスリ

Diamond Bent Files (Double heads)



6本セット/6pcs. set (木箱ケース入)

BF-70 (200全長/200 Long) ¥ 15,000/set

BF-80 (155全長/155 Long) ¥ 13,000/set

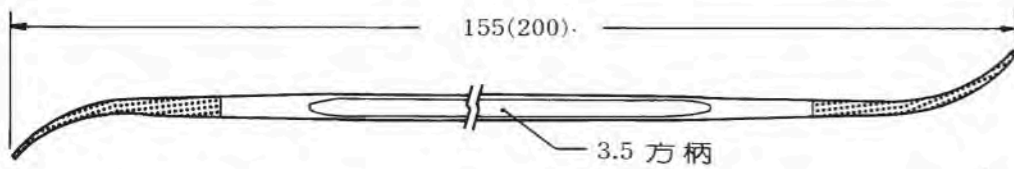

: mm

#: #200 #150		全長 Total length	No.	¥
		200	BF-701	2,400
		155	BF-801	2,100
		200	BF-702	2,400
		155	BF-802	2,100
		200	BF-703	2,400
		155	BF-806	2,100
		200	BF-704	2,400
		155	BF-803	2,100
		200	BF-705	2,400
		155	BF-804	2,100
		200	BF-706	2,400
		155		2,100



CF-40

ダイヤモンド・
テーパーハンドヤスリ
Diamond Hand Taper Files

 12本セット / 12pcs. set
CF-400 ¥16,000/set (PVC ケース入)

 : mm

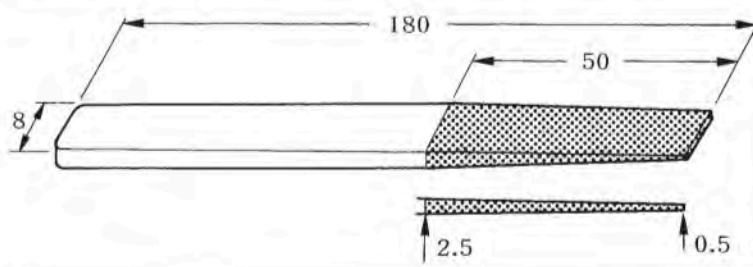
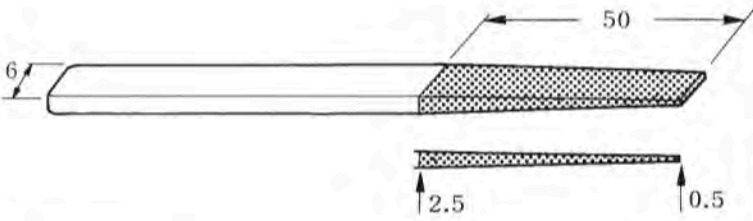
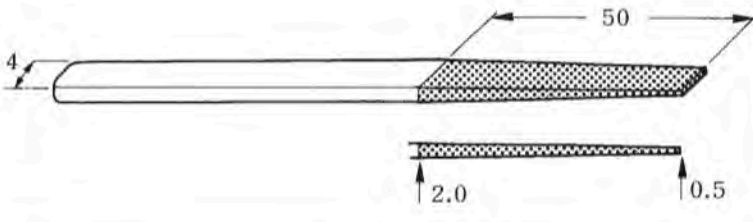
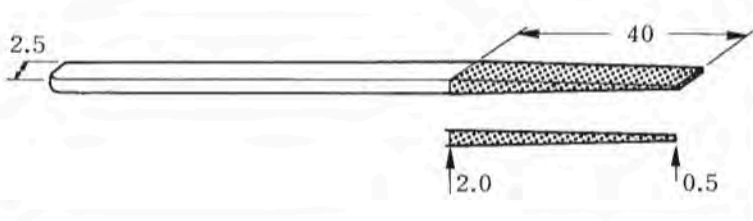
#: #150 #200 #400	No.	#	¥
	CF-408J	#150	1,750
	CF-408F	#200	1,750
	CF-408V	#400	1,750
	CF-406J	#150	1,450
	CF-406F	#200	1,450
	CF-406V	#400	1,450
	CF-404J	#150	1,150
	CF-404F	#200	1,150
	CF-404V	#400	1,150
	CF-402J	#150	1,000
	CF-402F	#200	1,000
	CF-402V	#400	1,000



IF/SF ダイヤモンドハンドヤスリ Diamond Hand Files

IF-50 タイプ / Type

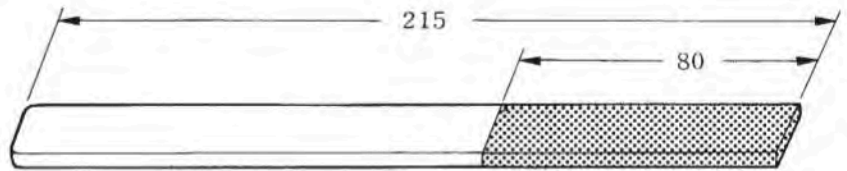

5 5本セット / 5 pcs. set
IF-500 ¥15,000/set (PVC ケース入)

: mm

# : #100	No.			¥
	IF-501		11×3.5	3,000
	IF-502		10.5×4.4	3,000
	IF-503		φ5	3,000
	IF-504		6.3	3,000
	IF-505		7.7	3,000

SF-80 タイプ / Type

# : #150	No.			¥
	SF-802		2×1	1,000
	SF-804		4×1	1,050
	SF-808		8×1	1,150

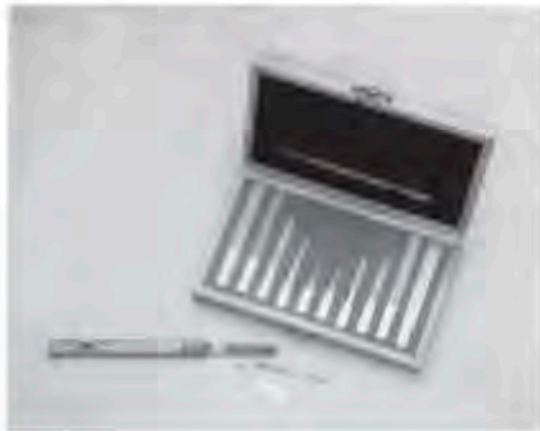

FA ダイヤモンド・チップヤスリ Diamond Tip Files

 10本セット/10pcs. set
 FAS-10 ¥16,000/set (木箱ケース入)
 (ピンバイス付/With Tool Holder)

 : mm

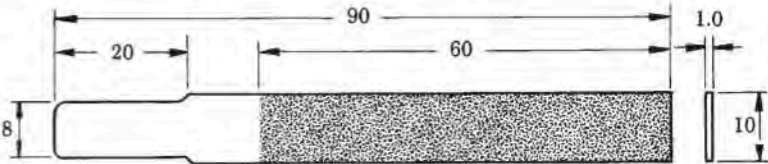
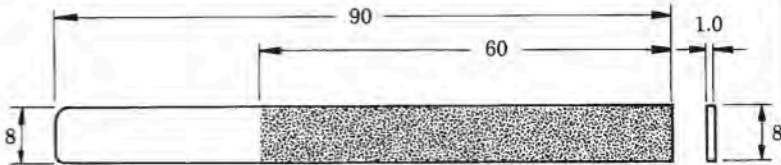
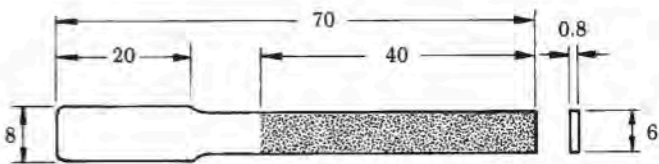
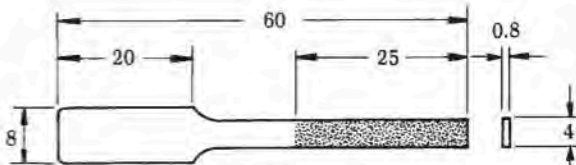
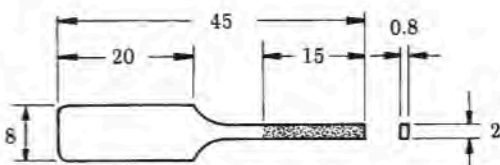
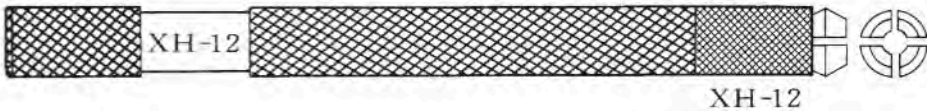
# : #200 #400 #150	No.	#	¥
	FA-101D	#150	2,300
	FA-102D	#200	2,300
	FA-104D	#400	2,300
	FA-081D	#150	1,800
	FA-082D	#200	1,800
	FA-084D	#400	1,800
	FA-061D	#150	900
	FA-062D	#200	900
	FA-064D	#400	900
	FA-041D	#150	900
	FA-042D	#200	900
	FA-044D	#400	900
	FA-021D	#150	900
	FA-022D	#200	900
	FA-024D	#400	900
			2,300

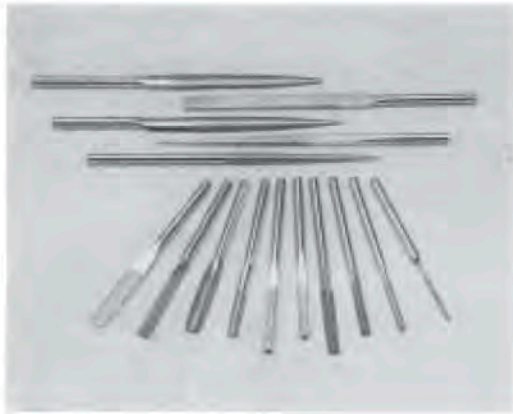

MF ダイヤモンド機械用ヤスリ ハンドファイリング用 Diamond Machine Files - For Hand Filing Machine

MF-10 タイプ / Type

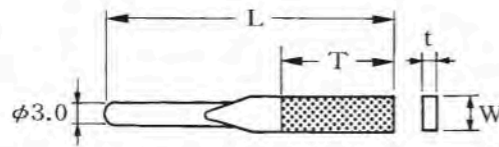

MF-101.....No.
3×1×20.... W×t×T
55..... L
各サイズ@¥1,000

#: #150

: mm

MF-101 3×1×15 50	MF-103 3×1×15 50	MF-105' 3×0.8×15 50	MF-107 3×1.4×20 55	MF-201 R1×15 50	MF-301 φ1×15 50	MF-401 2×15 50	MF-501 2×15 50
MF-102 5×1.8×20 55	MF-104 5×2×20 55	MF-106 3×1×20 55	MF-108 5.6×1.4×20 55	MF-202 R1.5×15 50	MF-302 φ2×15 50	MF-402 3×20 55	MF-502 3×20 55
				MF-203 R2×20 55	MF-303 φ3×20 55		
					MF-304 φ4×25 60		

MPF-10 タイプ / Type

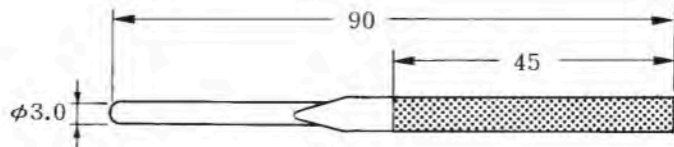

#: #150 #200

	No.			¥
	MPF-101		4×2	1,000
	MPF-102		5×2	1,000
	MPF-103		φ3	1,000
	MPF-104		2.5×2.5	1,000
	MPF-109		5×2	1,000

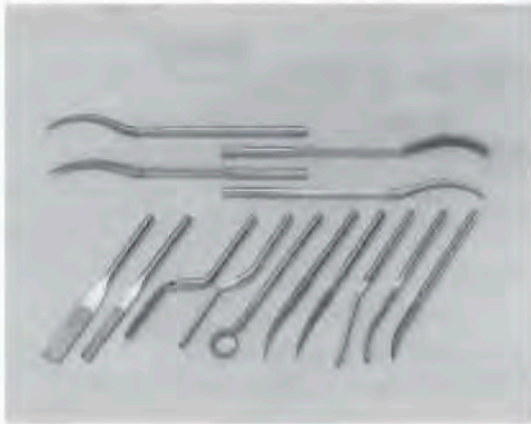

MBF ダイヤモンド機械用コテヤスリ ハンドファリング用 Diamond Machine Bent Files —For hand filing Machine.

: mm

MBF-90 タイプ / Type

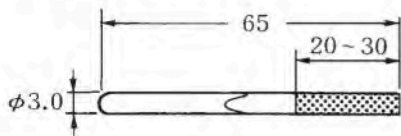

: (#150) (#200)

No.			¥
1. MBF-901		5.8×1.2	1,000
2. MBF-902		3.2×1.4	1,000
3. MBF-903		5×2	1,000
4. MBF-904		3.2×1.4	1,000
5. MBF-905		φ3	1,000
6. MBF-906		φ3	1,000
7. MBF-907		2.5 Side	1,000
8. MBF-908		3.2×1.4	1,000
9. MBF-909		3.2×1.4	1,000
10. MBF-910		4×2	1,000

MBF-60 タイプ / Type

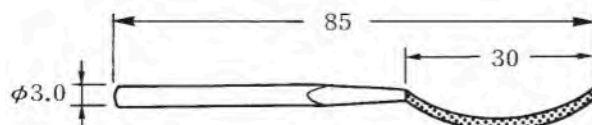

: (#150) (#200)

	No.			¥
	MBF-601		4×1.2	1,000
	MBF-602		5×2	1,000
	MBF-603		φ3	1,000
	MBF-604		2.5×2.5	1,000



PTF ダイヤモンド精密ヤスリ Diamond Needle Files

 10本セット/10pcs. set
 PTF-10 ¥11,000/set (ブレース入)
 PTF-10T ¥13,500/set (木箱ケース入)
 (ピンバイス付/With tool holder)

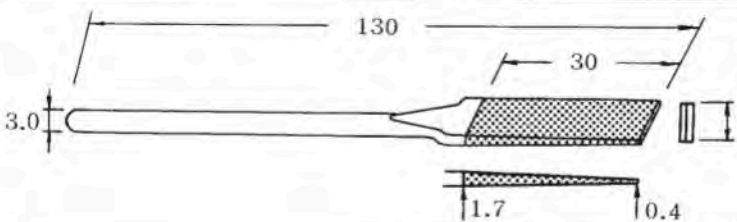
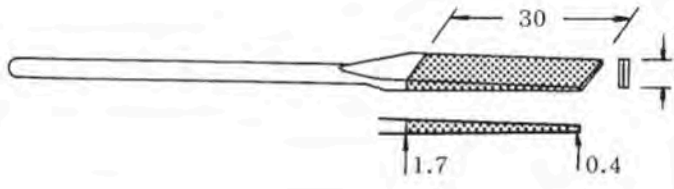
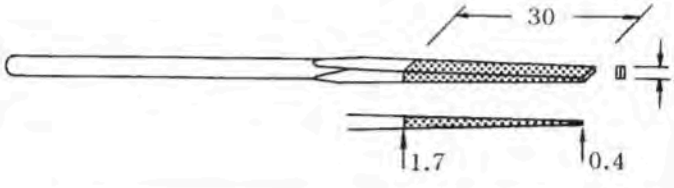
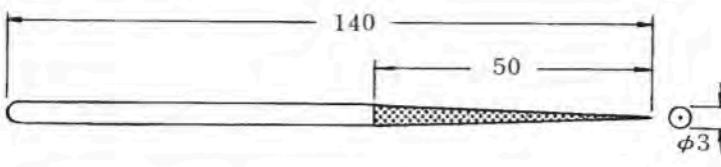
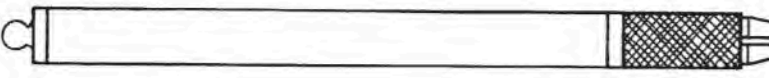
▬▬▬▬ : mm				
# : #200 #400 #600	No.	#	¥	
	PTF-16F	#200	1,150	
	PTF-16V	#400	1,150	
	PTF-16X	#600	1,150	
	PTF-14F	#200	1,100	
	PTF-14V	#400	1,100	
	PTF-14X	#600	1,100	
	PTF-12F	#200	1,000	
	PTF-12V	#400	1,000	
	PTF-12X	#600	1,000	
	PF-103X	#600	900	
	XH-22		2,300	



MCF-600 ダイヤモンド機械用ヤスリ Collected Diamond Machine File Set.

: mm

MCF-600 ¥ 24,000/set (木箱ケース入)

(20本セット・ピンバイス付/20 Pcs. Set with tool holder)

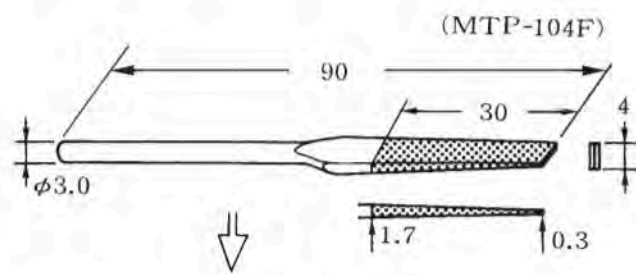
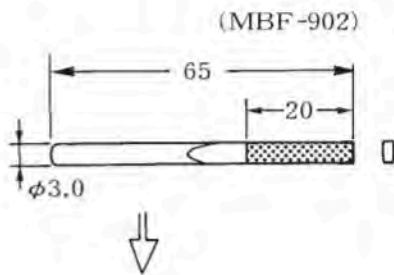

MCF-600 セット内容 /Contains one each of following :

No.			¥	No.			¥
MBF-901		5.8×1.2	1,000	MPF-101		4×2	1,000
MBF-902		3.2×1.4	1,000	MPF-102		5×2	1,000
MBF-903		5×2	1,000	MPF-103		φ3	1,000
MBF-904		3.2×1.4	1,000	MPF-104		2.5×2.5	1,000
MBF-905		φ3	1,000	MPF-109		5×2	1,000
MBF-906		φ3	1,000	MTF-13		3×1.4	1,100
MBF-907		2.5 Side	1,000	MTF-16		6×1.4	1,250
MBF-908		3.2×1.4	1,000	MTP-106		6×1.7	1,150
MBF-909		3.2×1.4	1,000	MTP-104		4×1.7	1,050
MBF-910		4×2	1,000	MTP-102		2×1.7	1,000

1.#: (#200) #400

2.ピンバイスの工具Noは XH-22 です。/The order no. of tool holder is XH-22.

3.このセットはハンドファイリング・超音波ラッピング・手作業用と兼用に使用できます。

MCF-600 can be applied on hand filing machine or ultrasonic lapping machine, also can be operated by hand with tool holder.



Precision Air Grinder

● Applications / 用途:

1. For clean up the burrs of casting , forging or plastics parts . / 清除鑄件, 鍛件, 塑膠件等之毛刺.
2. For grinding , engraving and polishing of mold and dies , as well as glass , stones , precious stone...etc./ 用於各種模具, 玻璃, 石材, 寶石等之研磨, 雕刻或拋光.
3. For grinding or smoothing the welding parts. / 焊接後之磨修.

<p>GP-260</p> 	<p>● Fixed chuck type / 夾頭固定式: $\varnothing 3.0\text{mm}$ chuck is standard. The tools with $\varnothing 3/32$ & $\varnothing 1/8$"chuck depend on request. / 標準品為$\varnothing 3.0\text{mm}$ 夾頭.$\varnothing 3/32$"& $\varnothing 1/8$"夾頭,請指明購買.</p>
<p>GP-380</p> 	<p>● Replaceable chuck type / 夾頭可換式: $\varnothing 3.0\text{mm}$ chuck is standard, $\varnothing 3/32$ & $\varnothing 1/8$" chuck are optional. / 標準品為$\varnothing 3.0\text{mm}$ 夾頭. $\varnothing 3/32$" & $\varnothing 1/8$"夾頭為選購品</p>
<p>GP-435</p> 	<p>● Twin-chuck type / 雙夾頭式: Two Collet chuck : $\varnothing 6.0\text{mm}$ & $\varnothing 3.0\text{mm}$ 雙夾頭:$\varnothing 6.0\text{mm}$ & $\varnothing 3.0\text{mm}$</p>
<p>GP-522</p> 	<p>● 120° Angle grinder / 120° 平面研磨機 Standard accessories: Cup wheel $\times 1$ pc. Rubber pad $\times 1$ pc. Paper disc $\times 9$ pcs. 標準配件:碗形輪, 橡膠盤各 1 個, 砂布片$\times 9$ 片</p>

● Specifications / 規格:

編號 Order no.	轉速 Free speed at 90 psi (rpm)	風流量 Air Consumption (m ³ /min.)	空氣壓力 Air Pressure recommend	尺寸 Dimensions $\varnothing D \times L$ (mm)	重量 Weight (g)	夾頭 Chuck Diameter (mm)
GP-260	60,000	0.18	90 psi	17.5 \times 142	180	* $\varnothing 3.0\text{mm}$
GP-380	80,000	0.17	90 psi	17.5 \times 143	160	* $\varnothing 3.0\text{mm}$
GP-435	35,000	0.26	90 psi	22 \times 160	350	$\varnothing 3$ & $\varnothing 6$ mm
GP-522	22,000	0.20	90 psi	16.5 \times 136	200	$\varnothing 30\text{mm}$ pad

* Standard Chuck , Others depend on request.

* 標準夾頭,其他夾頭請指明購買.



Lih[®] Pneumatic Lapping Machine

● Applications / 用途:

1. To quickly remove the hardened surface of mold, which was machined by EDM or wire-cut discharged machine.
迅速去除因放電加工或線切割後,金屬表面產生之硬化表層。
2. To lap especially, the areas of mold where are hard to lap by hand. Such as: the bottom or rib of gaps or slits.
尤其適於加工模具之窄溝槽底部,壁部或肋部,凹槽之邊角等不易研磨之部位。

往復行程 Reciprocating stroke	0.5 (mm)
往復頻率 Frequency	35,000 次 / 分 (strokes / min)
空氣消耗量 Air consumption	0.05 (m ³ / min)
空氣壓力 Air pressure recommend	90psi (maximum)
Dimensions / 尺寸	Ø23mm × 180mm (L)
Weight / 重量	250g

AR-05A 往復式氣動研磨機
(Patent Pending / 專利申請中)



往復行程 Reciprocating stroke	0.5 (mm)
往復頻率 Frequency	20,000 次 / 分 (strokes / min)
空氣消耗量 Air consumption	0.05 (m ³ / min)
空氣壓力 Air pressure recommend	90psi (maximum)
Dimensions / 尺寸	Ø30mm × 206mm (L)
Weight / 重量	265g

AR-07 渦輪式氣動研磨機
(Patent no. 138054 / 專利第 138054 號)



Turbolapper

往復行程 Reciprocating stroke	0~6 (mm)
往復頻率 Frequency	4,500 次 / 分 (strokes / min)
空氣壓力 Air pressure recommend	90psi (maximum)
空氣消耗量 Air consumption	0.08 (m ³ / min)
Weight / 重量	657g
Overall length / 全長	Ø30mm × 206mm (L)

AR-991 槍型氣動往復研磨機



Patent no. 111709
專利第 111709 號

左右行程 Lateral stroke	2 (mm)
搖擺頻率 Frequency	8,000 次 / 分 (strokes / min)
空氣壓力 Air pressure recommend	90psi (maximum)
空氣消耗量 Air consumption	0.05 (m ³ / min)
Weight / 重量	550g
Overall length / 全長	210mm

AR-993 左右式氣動研磨機
(Patent no. 121819 / 專利第 121819 號)



Standard Accessory / 標準配件

AR-05A

No.664 	No.665 	No.666 	No.701 
Ø3 & 1 mm Holder Ø3 & 1 mm 夾頭	1 mm Holder 1 mm 夾頭	Adjustable holder 可調式夾頭	Hex wrench 六角扳手

AR-07

No.662 	No.663 	No.666 	No.702 
3.2 mm Holder 3.2 mm 夾頭	6.3 mm Holder 6.3 mm 夾頭	Adjustable holder 可調式夾頭	Hex wrench 六角扳手





AR-991 & AR-993

No.661 	No.662 	No.663 	No.667 	No.702 
Ø3 & 1 mm Holder Ø3 & 1 mm 夾頭	3.2 mm Holder 3.2 mm 夾頭	6.3 mm Holder 6.3 mm 夾頭	Adjustable holder 可調式夾頭	Hex wrench 六角扳手

GP-522

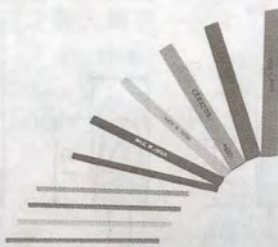
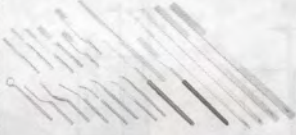
AGC 	AGS-01 	AGP-01 
Cup wheel 碗形輪	Paper disc 砂布片	Rubber pad 橡膠盤

Optional Tools / 選購工具

			
Oil polishing stone 油石	Ceramic super stone 超級油石	Diamond files 鑽石銼刀	Mounted point 帶柄砂輪
			
Diamond point 鑽石磨棒	Felt bobs 羊毛輪	Rubber point & Resinoid point 海棉砂輪 & 牛皮砂輪	



選用工具 / Optional Tools

帶柄砂輪 Mounted Points

可選購之柄徑 / Shank diameter available:
 $\phi 2.34$, $\phi 3.0$ and $\phi 3.175$ mm

"*" Just for $\phi 3.0$ and $\phi 3.175$ shank

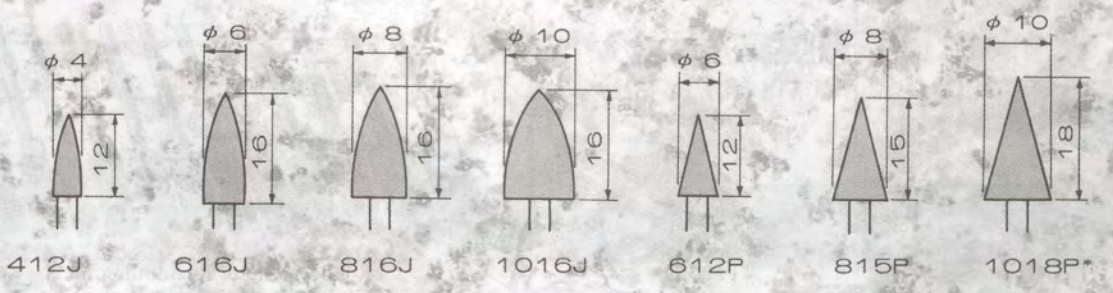
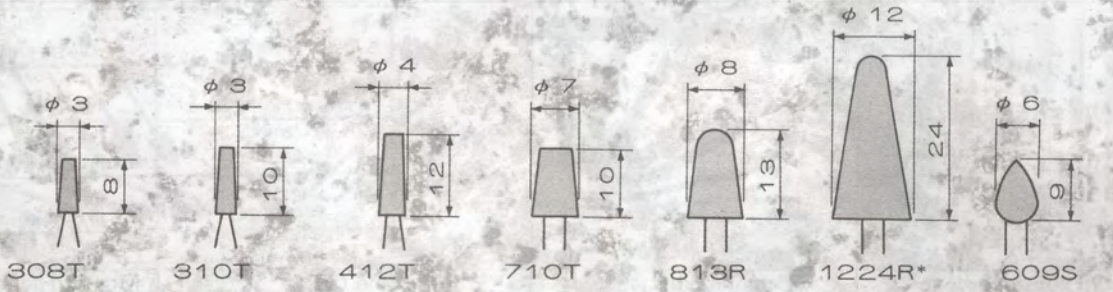
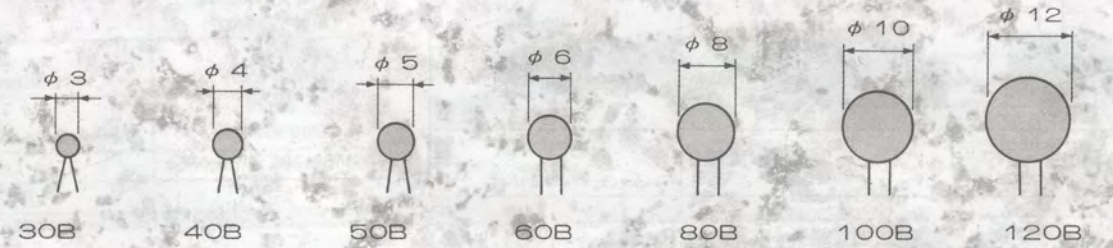
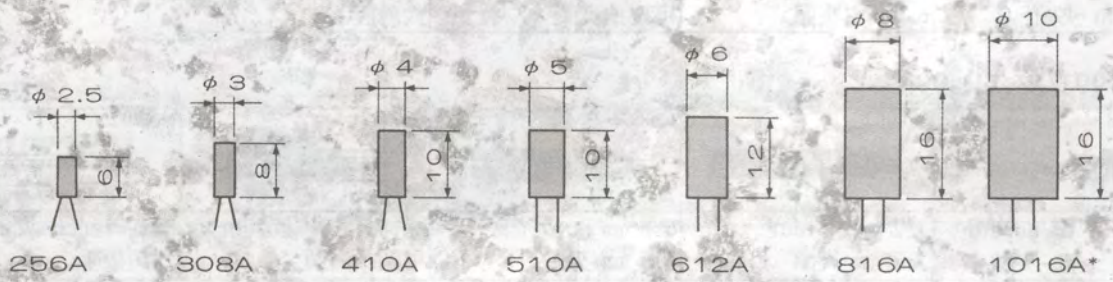



選用工具 / Optional Tools

帶柄砂輪與其他工具 Mounted Points & Other Tools

可選購之柄徑 / Shank diameter available:
φ2.34, φ3.0 & φ3.175mm

"*" Just for φ3.0 and φ3.175 shank

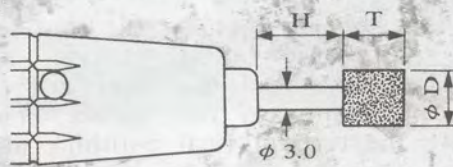
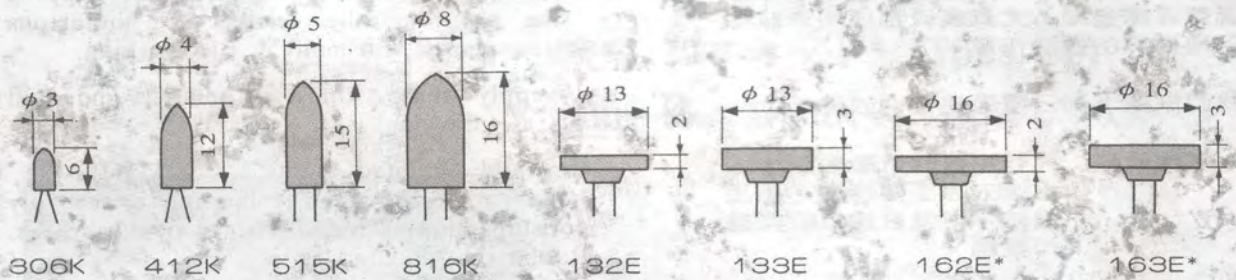

※ H : 柄之懸空長度 / The length of overhanging

* 爲了您的安全，於使用砂輪時，
請勿超過右表所列之最大轉速。

For your security, please keep the rotation not exceed the Max. R.P.M. as listed belows:

φ D (mm)	T (mm)	H(mm)		
		13mm	25mm	38mm
3.0	13	105000	64000	46650
6.0	13	60000	38000	26250
9.5	13	45370	28500	21000
9.5	25	26250	18750	14250
13	13	34500	22500	16870
13	25	20620	13870	10120

GP-522專用工具 / The Tools For GP-522

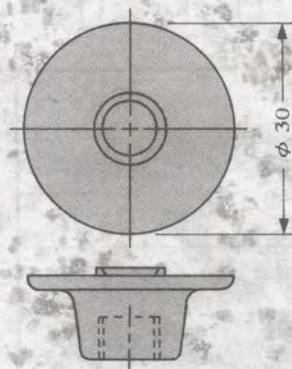

橡膠皿
Rubber Pad

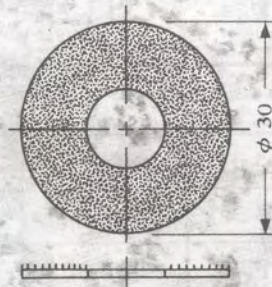

粒度 / Grit size:
#60, #100, #150

砂布片
Paper Disc

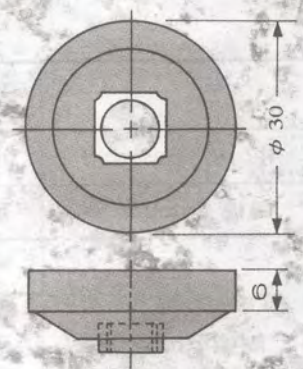

碗形砂輪
Cup Wheels



選用工具 / Optional Tools

彈性帶柄砂輪 Elastic Mounted Points

可選購之柄徑 / Shank diameter available:
 $\phi 2.34$, $\phi 3.0$ & $\phi 3.175$ mm

彈性帶柄砂輪主要使用來拋磨各種鐵金屬或非鐵金屬，尤其廣泛地運用來做為各種模具的拋磨作業。

我們供應下列三種彈性帶柄砂輪：

- * 牛皮砂輪：具有良好的研磨性能，可迅速去除工件表面之加工痕跡，可當做初步的拋磨作業用。
- * 海棉砂輪：銳利性較差，卻有良好的拋光效果，可得較細緻的表面光度。
- * 陶瓷砂輪：優異的耐久性及拋光效果，適合精細拋光，並可大量減少後序的拋光作業時間。

Elastic Mounted Points are used for lapping or fine polishing the ferrous & nonferrous metals, specials, on mold & die working.

We supply three kinds of elastic mounted points as following:

- * Resinoid Mounted Points:
Used for stock removal lapping or roughly polishing the machined surface of workpiece.
- * Rubberize Mounted Points:
Compare to these resinoid points, they are not so "sharp", but it can get better lapping surface.
- * Ceramic Mounted Points:
Like these rubberize points, it have good lapping performance, but they have much better durability. And the finer grit size points can obtain very fine surface, it can cut down the time of final polishing afterward.

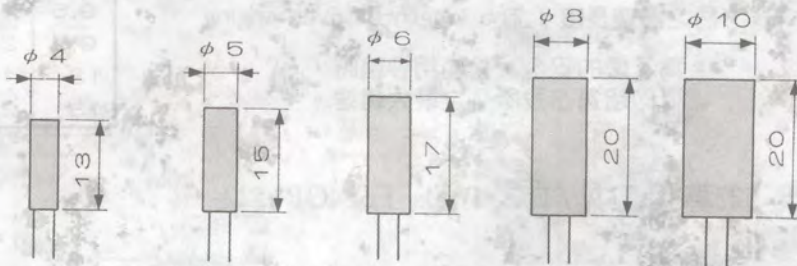

	粒度 Grit Siz	No.				
牛皮 / Resinoid	# 120	N413	N515	N617	N820	N1020
海棉 / Rubberize	# 120	R413	R515	R617	R820	R1020
陶瓷 / Ceramic	#220	C413F	C515F	C617F	C820F	C1020F
	#320	C413V	C515V	C617V	C820V	C1020V
	#400	C413S	C515S	C617S	C820S	C1020S
	#600	C413X	C515X	C617X	C820X	C1020X

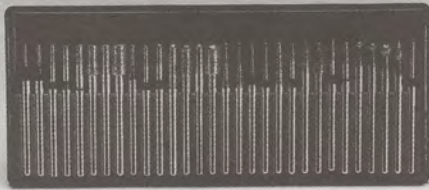

選用工具 / Optional Tools

鑽石帶柄砂輪 Diamond Mounted Points

可選購之柄徑 / Shank diameter available:
φ3.0 and φ3.175mm

BM Series

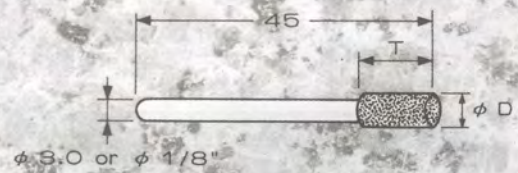

BMS-30 (30pcs. set)

Contains one each of following:

Unit : mm

NO.	BM10A	BM15A	BM20A	BM25A	BM30A	BM35A	BM40A	BM50A	BM15C	BM20C
φ D	1.0	1.5	2.0	2.5	3.0	3.5	4.0	5.0	1.5	2.0
T	7	7	7	7	7	7	10	10	7	7

NO.	BM25C	BM30C	BM35C	BM40C	BM50C	BM20P	BM30P	BM15R	BM20R	BM30R
φ D	2.5	3.0	3.5	4.0	5.0	2.0	3.0	1.5	2.0	3.0
T	7	7	7	10	10	12	15	12	12	14

NO.	BM20F	BM30F	BM50F	BM20T	BM30T	BM20B	BM30B	BM50B	BM30S	BM30V
φ D	2.0	3.0	5.0	2.0	3.0	2.0	3.0	5.0	3.0	3.0
T	7	7	10	7	7	-	-	-	6	7

訂購時，請指明柄徑，若無指定將以φ 3.0mm 柄徑供應。

When ordering, please specify shank diameter is φ 3.0mm or φ 3.175mm.

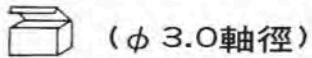

BMS ダイヤモンドバーセット / Diamond Mounted Point Set

BMB CBN バーセット / CBN Mounted Point Set

30本セット / 30pcs. set

MBS-30 ¥ 9,000/set (アクリルケース入)

¥ 9,500/set (木箱ケース入)

BMB-30 ¥ 10,000/set (アクリルケース入)

¥ 10,000/set (木箱ケース入)

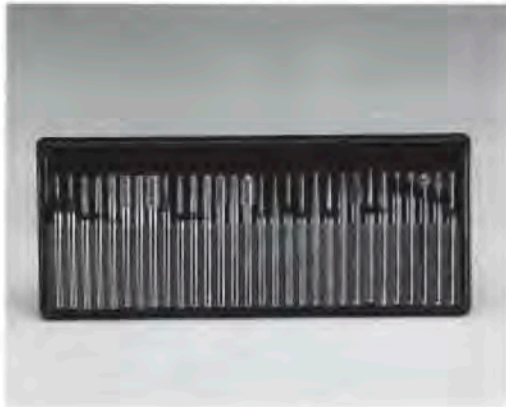

セット内容 / Contains one each as below:

10A, 15A, 20A, 25A, 30A, 35A,

40A, 50A, 20B, 30B, 50B, 15C,

20C, 25C, 30C, 35C, 40C, 50C,

20P, 30P, 15R, 20R, 30R, 30S,

20F, 30F, 50F, 20T, 30T, 30V,

(各1本)

20本セット / 20pcs. set

BMS-20 ¥ 6,000/set (プラスチックケース入)

BMB-20 ¥ 6,500/set (プラスチックケース入)



セット内容 / Contains one each as below:

10A, 15A, 20A, 25A, 30A, 35A,

15C, 20C, 25C, 30C, 20P, 30P,

15R, 20R, 30R, 20B, 30B, 20F,

30F, 20T, (各1本)



BM (φ 3.0軸径)

ダイヤモンド・CBNバー

Diamond・CBN Mounted Point

#: #120

: mm

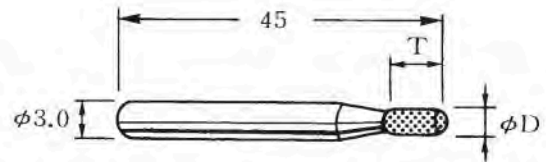

Order No.	10A*	15A*	20A*	25A*	30A*	35A*	40A*	50A*	60A	15B	20B*	30B*	40B	50B*	60B
φD	1.0	1.5	2.0	2.5	3.0	3.5	4.0	5.0	6.0	1.5	2.0	3.0	4.0	5.0	6.0
T	6	6	7	7	7	7	10	10	10	-	-	-	-	-	-
¥	290					380				290				380	

Order No.	10C	15C*	20C*	25C*	30C*	35C*	40C*	50C*	60C	20P*	30P*	60P	15R*	20R*	30R*			
φD	1.0	1.5	2.0	2.5	3.0	3.5	4.0	5.0	6.0	2.0	3.0	6.0	1.5	2.0	3.0			
T	6	6	7	7	7	7	10	10	10	12	15	13	12	12	14			
¥	290					380				290			380			290		

Order No.	30S*	20F*	30F*	40F	50F*	60F	30J	60J	20T*	30T*	30Q	60Q	30V*	220E
φD	3.0	2.0	3.0	4.0	5.0	6.0	3.0	6.0	2.0	3.0	3.0	6.0	3.0	22
T	6	7	7	10	10	10	14	13	7	7	5	10	7	0.7
¥	290			380			290	380	290			380	290	1,800

ダイヤモンドバー / Diamond Engraving Burr

BH タイプ / Type

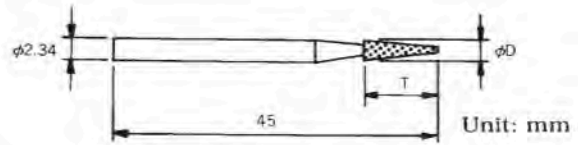

Order No. D1 D2 D3 D4	A11 A12 A13	A21 A30	7A 8A
ϕD 1 2 3 4	1 1.5 1.5	2.5 3	7 8
T - - -	5 5 7	7 7	6 10
Order No. A20 A31	TR 1R	KS	RZ
ϕD 2.5 3	1.5 1.5	3.5	4
T 7 7	8 10	6	6
Order No. T11 T12 T13	1A 2A 2LA	3A 5A 6A	2LB
ϕD 1 1.5 2	2 2.5 2.5	3 4 5	2.5
T 4 4 4	8 12 10	10 10 10	12
Order No. 1LR 2R 2LR	3R 5R 6R 7R 8R	C3 C13 C23	
ϕD 1.5 2 2.5	3 4 5 7 8	0.9 1.5 2	
T 10 12 12	12 12 12 12 12	4 10 10	
Order No. 12BA 14BA 16BA 19BA	Kr5 Kr8 Kr9	K6 K10	KA
ϕD 4 6 10 12	6 8 8	2 2.5 7	7
T - - -	23 1.5 2 3	5 7 12	12

ダイヤモンドバー / Diamond Engraving Burr

	45°		45°		15°		60°
Order No.	10B 12B 13B 14B 16B	16BB	16BC	13nk			
φD	2.7 4 5 6 10	10	10	5			
T	- - - - -	-	-	-			
Order No.	RT	10X 17X 18X 19X 23X	10BN 12BN 13BN				
φD	5	1.8 4 6 10 16	2.5 4 5				
T	7	0.5 0.8 1 1.6 2	- - -				
Order No.	K25 K30 K35 K45 K50 K55 K60	20mA					
φD	4 5 6 10 10 12 12	20					
T	0.4 0.6 0.5 0.5 1 0.6 1	3.5					
Order No.	13mB 16mC 16mB	10mA 13mA 16mA					
φD	13 16 16	10 13 16					
T	2.5 2.5 3.5	2.5 3.5 3.5					
Order No.	88D	88C	88A				
φD	22	22	22				
T	0.45	0.35	0.45				



ID·IB ダイヤモンド・CBN 軸付インターナル砥石 Diamond・CBN Internal Grinding Wheel.

ダイヤモンド /Diamond : ID-XXXX
CBN : IB-XXXX

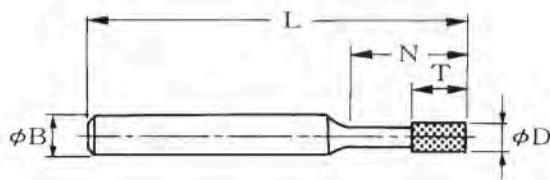

: mm

No.	φD	T	N	L	φB	#	¥(ダイヤ)	¥(CBN)
3004	0.4	2	5	45	3.0	#400	1,050	1,050
3005	0.5	2	8	45	3.0	#400	1,050	1,050
3006	0.6	3	8	45	3.0	#200	1,050	1,050
3007	0.7	3	8	45	3.0	#200	1,000	1,000
3008	0.8	3	8	45	3.0	#200	1,000	1,000
3009	0.9	4	8	45	3.0	#200	1,000	1,000
3010	1.0	5	8	45	3.0	#200	900	900
3015	1.5	5	8	45	3.0	#150	900	900
3020	2.0	5	12	45	3.0	#150	900	900
3025	2.5	5	15	45	3.0	#150	900	900
3030	3.0	5	15	45	3.0	#150	900	900
3040	4.0	5	-	50	3.0	#150	1,000	1,000
3050	5.0	8	-	50	3.0	#150	1,000	1,000
3060	6.0	8	-	50	3.0	#150	1,000	1,000
6040	4.0	10	22	80	6.0	#100	1,000	1,000
6050	5.0	10	22	80	6.0	#100	1,000	1,000
6060	6.0	10	22	80	6.0	#100	1,000	1,000
6070	7.0	10	-	80	6.0	#100	1,200	1,350
6080	8.0	10	-	80	6.0	#100	1,350	1,500
6090	9.0	10	-	80	6.0	#100	1,500	1,650
6100	10	10	-	80	6.0	#100	1,650	1,800
6120	12	10	-	80	6.0	#100	1,950	2,100
6140	14	10	-	80	6.0	#100	2,250	2,400
6160	16	10	-	80	6.0	#100	2,550	2,850
6180	18	10	-	80	6.0	#100	3,000	3,300
6200	20	10	-	80	6.0	#100	3,300	3,600



BC (軸径φ6.0)
ダイヤモンドバー
Diamond Mounted Wheels

: (#40) (#60) (#100)

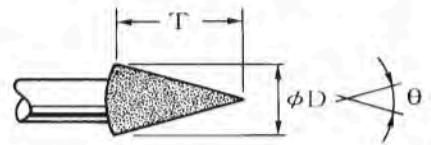
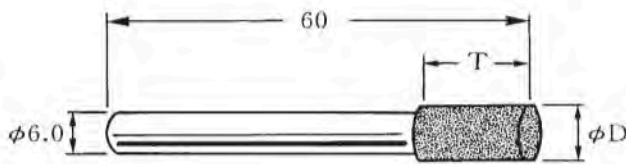

: mm

No.	BC80B*	BC100B	BC80V*	BC100E*	BC65C*	BC80C	BC100C	BC65A	BC80A*	BC100A
φD	8.0	10	8	10	6.5	8.0	10	6.5	8.0	10
T	-	-	-	1.2	15	15	19	15	15	19
θ	-	-	20°	-	-	-	-	-	-	-

No.	BC80P*	BC100P	BC80T*	BC100N	BC65F*	BC80F*	BC100F	BC100Q	BC65R	BC100J
φD	8.0	10	8.0	10	6.5	8.0	10	10	6.5	10
T	-	-	15	-	22	15	19	16	25	19
θ	30°	28°	15°	90	-	-	-	-	10	-

BC-10 10本入セット / 10 pcs. set ¥15,000(#40) ¥12,000(#60), ¥11,000(#100)

セット内容 / Contains One each of following :

BC80B BC80V, BC100E, BC65C, BC80A

BC80P, BC80T, BC65F, BC80F, BC65R(各1本)

TUNGSTEN CARBIDE BURRS

SHANK DIA - DIAMOND CUT

6.0 mm.



CP-6



CR-6



TR-6



TP-6

ดอกเจียรคาร์ไบด์แกน 6 มม.

CYLINDER		แกน 6 มม.		
รหัส No.	ความโตคมตัด (มม.)	ความยาวคมตัด (มม.)	ความยาวทั้งหมด (มม.)	
CP-6	10	19	65	
CR-6	10	19	65	
TR-6	10	19	65	
TP-6	10	19	65	



TV-6



SB-6



CT-6







































IC-6

ดอกเจียรคาร์ไบด์

BALL NOSED CYLINDER		แกน 6 มม.		
รหัส No.	ความโตคมตัด (มม.)	ความยาวคมตัด (มม.)	ความยาวทั้งหมด (มม.)	
TV-6	10	16	60	
SB-6	10	9	53	
CT-6	10	16	65	
IC-6	6	7	50	

หัวเจียรคาร์ไบด์ / SOLID CARBIDE BURS U.S.A.

3mm Shank	Order no	Cutter Diameter	Cutter Length	3mm Shank	Order no	Cutter Diameter	Cutter Length
	CP-1	3	15		SB-1	-	3
	CP-1A*	2.4	13		SB-1A	-	2
	CP-1B*	1.5	6		SF-1	3	7
	CR-1	3	15		ST-1	3	13
	CR-1A	2.4	11		ST-1A	3	10
	CT-1	3	16		TP-1	3	15
	CT-1A	3	11		TP-1A	3	10
	CT-1B	3	9		TR-1	3	15
	IC-1	3	5		TR-1A	3	8
	IC-1A	2	3		TV-1	3	6
	JE-1	-	3	* มี 2 แบบ 1. End Cut / มีลาย 2. Solid / เรียบ			
3mm Shank-6mm Head	Order no	Cutter Diameter	Cutter Length	6mm Shank-10mm Head	Order no	Cutter Diameter	Cutter Length
	CP-2	6	13		CP-6	10	20
	CR-2	6	14		CR-6	10	20
	TR-2	6	14		TR-6	10	20
	TP-2	6	14		TP-6	10	25
	TV-2	6	10		TV-6	10	16
	SB-2	6	-		SB-6	10	10
	CT-2	6	14		CT-6	10	20
	IC-2	6	6		IC-6	10	16

คาร์ไบด์แท่งกลม-สวีเดน / Carbide Rod-Sweden

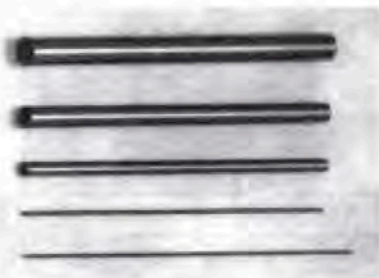

คาร์ไบด์ชนิดแท่งกลมยาว 100 ม. ทุกขนาดเป็นคาร์ไบด์ชนิดไมโครเกรนมีความแข็งแรงเหนียว จึงเหมาะแก่การนำไปแต่งเป็นรูปร่างต่างๆ ใช้กัดแต่งแม่พิมพ์

เส้นผ่าศูนย์กลาง Diameter	ความยาว Length
3	100
4	100
5	100
6	100
8	100
10	100
12	100
14	100
16	100
20	100

鑽石拋磨工具
DIAMOND POLISHING TOOLS





鑽石微粉

Diamond Micron Powder

鑽石微粉乃經過精密設備嚴格篩選，粒度尺寸精確、顆粒結晶形狀劃一。它適用於各種鋼模、超硬合金、陶瓷、寶石、半寶石等之精密拋光或鏡面研磨。

micron powders are precision graded from virgin material and especially designed for lapping and polishing operations. Particularly, those requiring the strictest dimensions accuracy and the finest surface finish.

■種類：

R 級：R 級系列之鑽石微粉，其顆粒形狀較不規則，易碎，較銳利之切削性。較適用於HRC50以下之鋼模拋光。

M 級：M 級系列之鑽石微粉，其顆粒形狀較規則，切刃較強韌。較適用於各種超硬合金、陶瓷等之拋光作業。

■Type:

R Series: Which particles are irregular, and more friable basic crystal structures. Which is used where a more free-cutting action is required.

M Series: Which particles are more regular than R series and more durable basic crystal structure. Which is used where a more heavy duty finishing action is required.

■包裝：每罐50克拉或100 克拉裝。

■Containers: 50 carats or 100 carats per vial.

■規格 / Specifications:

粒 度 MESH SIZE	顆粒尺寸 MICRON RANGE (μ m)	R 級 (R TYPE)		M 級 (M TYPE)	
		10 cts	50 cts	10 cts	50 cts
#200	90 (80-100)	DR-1002	DR-5002	DM-1002	DM-5002
#400	50 (40-60)	DR-1004	DR-5004	DM-1004	DM-5004
#600	35 (30-40)	DR-1006	DR-5006	DM-1006	DM-5006
#800	25 (20-30)	DR-1008	DR-5008	DM-1008	DM-5008
#1,200	15 (10-20)	DR-1012	DR-5012	DM-1012	DM-5012
#1,800	9 (6-12)	DR-1018	DR-5018	DM-1018	DM-5018
#3,000	9 (4-8)	DR-1030	DR-5030	DM-1030	DM-5030
#5,000	4.5 (3-6)	DR-1050	DR-5050	DM-1050	DM-5050
#8,000	3 (2-4)	DR-1080	DR-5080	DM-1080	DM-5080
#14,000	1 (0-2)	DR-1140	DR-5140	DM-1140	DM-5140
#28,000	0.5 (0-1)	DR-1280	DR-5280	DM-1280	DM-5280

鑽石膏 Diamond Compounds



鑽石膏係採用嚴格精密篩選之鑽石微粉，及獨特配方之助削混合劑，提供您最有效率及精確的拋光作業。適用於各種鋼模、錳鋼模、精密陶瓷、金相試片等之拋光及鏡面拋光。

diamond compounds are made of precisely graded diamond powders and carries, Which is the most efficient and precise polishing tools. It can use for polishing carbide dies, steel mold, ceramic parts and metal testing specimen.

■種類：有油溶性及水溶性兩種。

■Carrier Classifications: Oil soluble or water soluble.

■包裝：注射桶式包裝，每支 5 公克裝。
(其他容量亦可指明訂製)

■Containers: Plastic syringes, 5 grams per syringe. (Other containers depend on your request.)

■鑽石粉含量：分為標準濃度及高濃度兩種。

■Diamond Concentrations: Medium or heavy concentrations.

規格 / Specifications:

編號 (ORDER NO.)		顆粒尺寸 MICRON RANGE (μ m)	相等篩目 MESH SIZE	標示顏色 COLOR	價格 (PRICE)	
標準級 MEDIUM	高濃度 HEAVY				標準 MEDIUM	高濃度 HEAVY
PDR-280	PDM-280	0.5 (0-1)	#28,000	GREY 灰		
PDR-140	PDM-140	1 (0-2)	#14,000	WHITE 白		
PDR-080	PDM-080	3 (2-4)	#8,000	YELLOW 黃		
PDR-050	PDM-050	4.5 (3-6)	#5,000	LIGHT BROWN 淺棕色		
PDR-030	PDM-030	6 (4-8)	#3,000	ORANGE 橙		
PDR-020	PDM-020	8 (6-10)	#2,000	LILAC 淺紫		
PDR-018	PDM-018	9 (6-12)	#1,800	GREEN 綠		
PDR-015	PDM-015	13 (10-16)	#1,500	PINK 粉紅		
PDR-012	PDM-012	15 (10-20)	#1,200	BLUE 藍		
PDR-010	PDM-010	17.5 (15-20)	#1,000	DARK GREEN 深綠		
PDR-008	PDM-008	25 (20-30)	#800	BROWN 咖啡		
PDR-006	PDM-006	35 (30-40)	#600	RED 紅		
PDR-004	PDM-004	50 (40-60)	#400	PURPLE 紫		
PDR-002	PDM-002	90 (80-100)	#200	BLACK 黑		

說明：1. 標準規格品為油溶性，若需水溶性鑽石膏，請指明訂購。
2. 請配合本公司的稀釋油使用，可使拋光效果更佳。

Note: 1. Oil soluble is standard carries, other carries depend on your requirement.
2. We also supply thinners, help you to do better polishing performance.

鑽石膏用木條 Lapping Wood Sticks



○	AFW-01H φ3.2	AFW-02H φ4.7	AFW-03H φ6.4	AFW-04H φ9.5
□	AFW-05H 6.4 × 6.4			
▭	AFW-06H 3.2 × 6.4	AFW-07H 3.2 × 9.5	AFW-08H 6.5 × 12.7	

鑽石膏用帶柄木棒 Wood Bobs

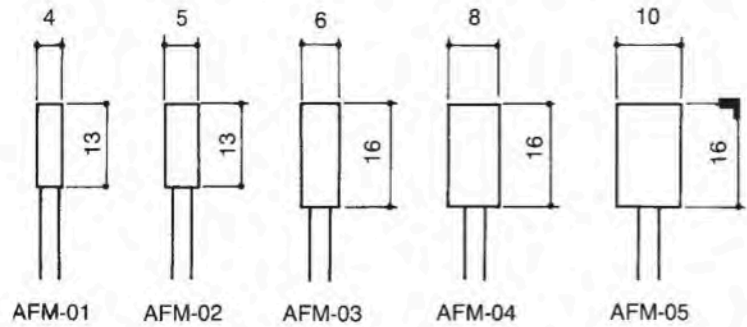

棕 刷 / Brush

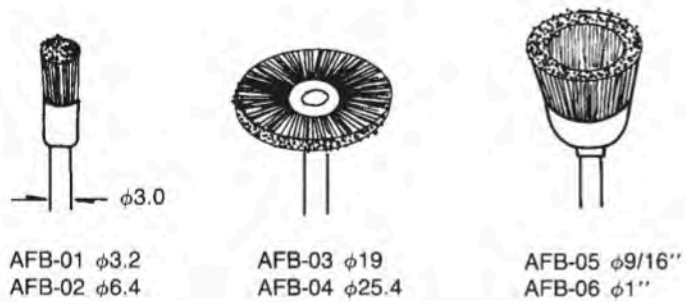



ลูกขัดสักหลอด / FELT BOBS

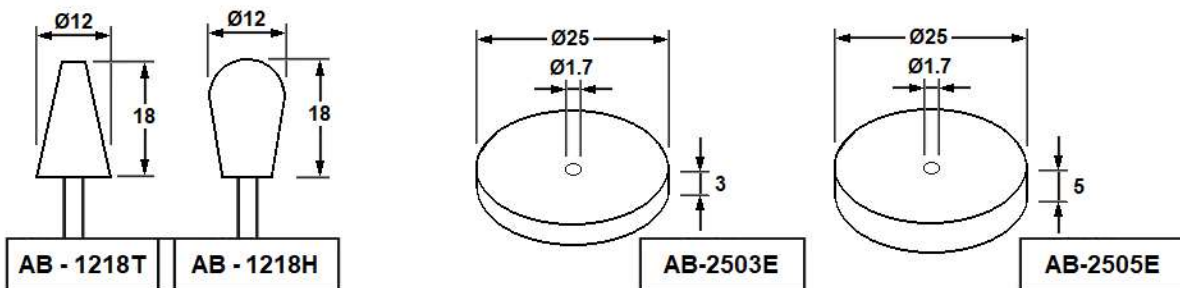
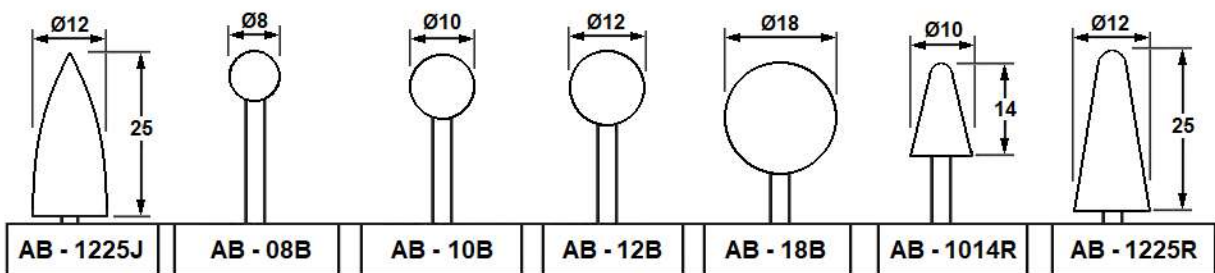
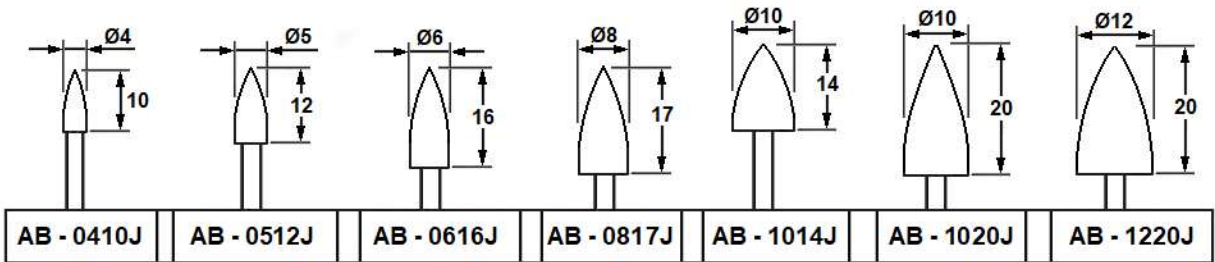
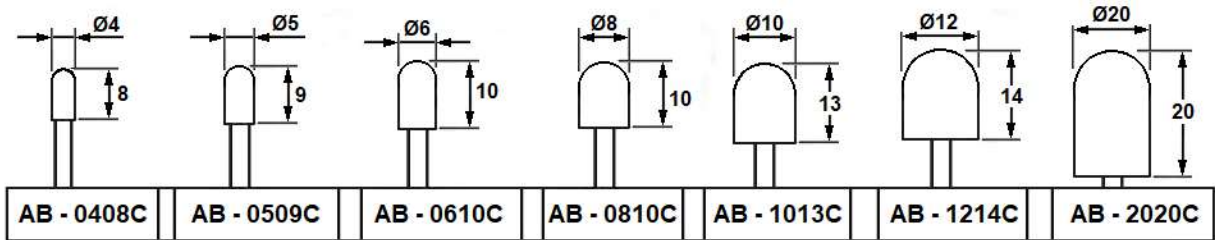
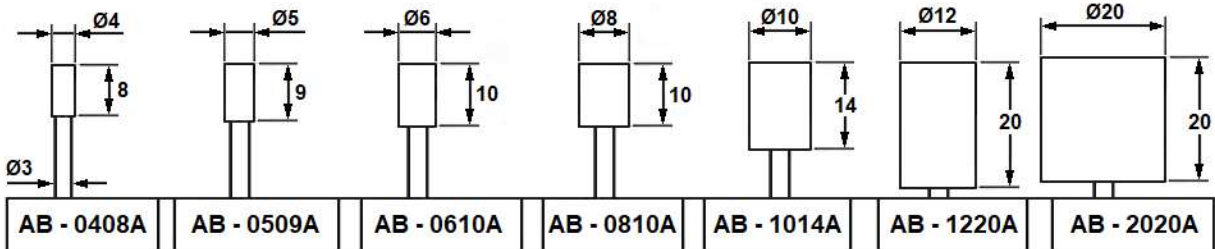



鑽石油石 Resin Bond Diamond Stones.

■鑽石油石適用於各種切削刀具研磨後之最後刃部修整，以增加刀具壽命及切削光製度。亦可適用於模具或工件之拋光作業。

■Diamond stone is suitable for final finishing the cutting tools. Which can enhance the tools life and improve the machined surface of workpiece. Besides, it can be used for lapping the mold and die.

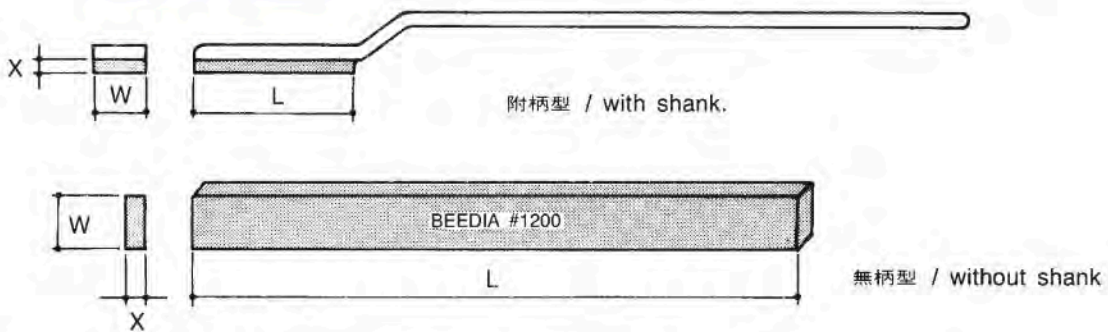

SIZE NO. 尺寸代號	SIZE (mm) 尺寸				NOTE 備註
	W	L	X	R	
01	10	40	2.0		WITH SHANK (附柄)
02	5	40	2.0		WITH SHANK (附柄)
03	5	40	4.0	2.5	WITH SHANK (附柄)
04	10	120	3.2		WITHOUT SHANK (不附柄)
05	6	100	3.0		WITHOUT SHANK (不附柄)
06	4	100	4.0		WITHOUT SHANK (不附柄)

■規格 / Specifications:

SIZE NO. 尺寸代號	粒度及產品代號 GRIT SIZE & ORDER NO.										
	#100	#200	#400	#600	#800	#1000	#1200	#1800	#3000	#5000	#8000
01	—	RSH-0102	RSH-0104	RSH-0106	RSH-0108	RSH-0110	RSH-0112	RSH-0118	—	—	—
02	—	RSH-0202	RSH-0204	RSH-0206	RSH-0208	RSH-0210	RSH-0212	RSH-0218	—	—	—
03	—	RSH-0302	RSH-0304	RSH-0306	RSH-0308	RSH-0310	RSH-0312	RSH-0318	—	—	—
04	RS-0401	RS-0402	RS-0404	RS-0406	RS-0408	RS-0410	RS-0412	RS-0418	RS-0430	RS-0450	RS-0480
05	RS-0501	RS-0502	RS-0504	RS-0506	RS-0508	RS-0510	RS-0512	RS-0518	—	—	—
06	RS-0601	RS-0602	RS-0604	RS-0606	RS-0608	RS-0610	RS-0612	RS-0618	—	—	—



鑽石砂紙 Diamond Foils

■鑽石砂紙是一種具有廣泛用途的工具，它可以用來磨去各種模具的機械加工痕跡，亦可做為機器的止滑裝置。其最大的優點是可以自由裁成所需形狀及尺寸，做成所需的工具。

■Diamond foils is designed for lapping the machined surface of mold and die. You can cut it to any shape and size to meet your special needs.

■尺寸 / Size:
10 × 100 (mm)
50 × 100 (mm)
100 × 100 (mm)

■粒度 (Grit Size):
#120, #150, #200,
#300, #400, #600,
#800, #1,200, #1,800

規格 / Specifications

尺寸 / Size	粒度與編號 / Grit Size & Order No.								
	#120	#150	#200	#300	#400	#600	#800	#1200	#1800
10×100mm	XF-1012	XF-1015	XF-1020	XF-1030	XF-1040	XF-1060	XF-1080	XF-1120	XF-1180
50×100mm	XF-2012	XF-2015	XF-2020	XF-2030	XF-2040	XF-2060	XF-2080	XF-2120	XF-2180
100×100mm	XF-3012	XF-3015	XF-3020	XF-3030	XF-3040	XF-3060	XF-3080	XF-3120	XF-3180

*除上述尺寸及粒度外，其他規格亦歡迎訂製。
Besides above specifications upon your request

專用工具 / Tools For Diamond Foils

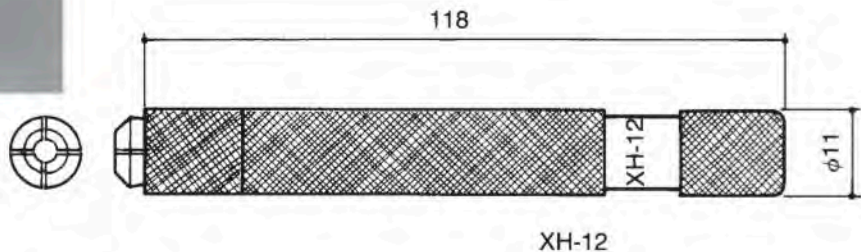
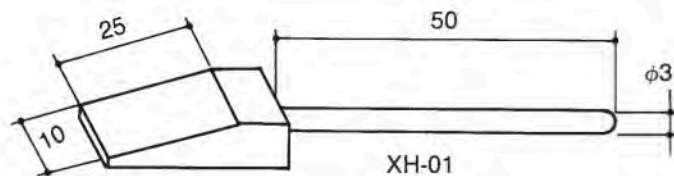

夾頭可夾持尺寸 / Collet capacity:
圓柄可夾持尺寸 / For Round Shank: $\phi 3\text{mm} \sim \phi 3.175\text{mm}$
扁柄可夾持尺寸 / For Flat Shank: 0.4mm ~ 0.9mm Thickness

CERATON[®] SERIES

1998.3

CERAMIC STONES 超級油石

可平面研磨的陶瓷纖維油石

新上市

STICK TYPE (扁平型)



ROUND TYPE (圓棒型)



〈說明〉

陶瓷纖維油石（俗稱超級油石）係將高純度之陶瓷纖維以熱塑性樹脂結合製造而成，具有高硬度、耐磨耗及不易折斷的特性。除可用於手持研磨外且適用於氣動、電動往復式研磨機上使用。尤其在超音波振動研磨機上使用，更有優異的效果！

〈適用材質〉

CERATON 陶瓷纖維油石可在許多不同的材質上作研磨加工：例如各種模具鋼材、不銹鋼、銅鋁合金...等。舉凡模具、齒輪、沖子、刀具...等物件的粗糙表面都可利用陶瓷纖維油石來打磨。

〈適用範圍〉

CERATON 陶瓷纖維油石最適用於一般難研磨加工處，如窄溝壁、溝底、孔、刻痕、肋部及微小精細處，皆可由放電加工面研磨至精細之表面。

〈特性〉

CERATON 陶瓷纖維油石除了具有市上原有產品的效能外，更增加了平面研磨的功效。此外，售價也更為低廉。

日本 CERATON® 超級油石

JAPAN CERAMIC STONE SERIES

本產品共有九種不同粗細
粒度，由180 至1200#
由不同顏色來區隔分辨。
使用時可依研磨工件表面
的粗細度來選取。

R		#1200	NB		#360
P		#1000	BL		#280
Y		#700	OR		#250
G		#500	BR		#180
B		#400			

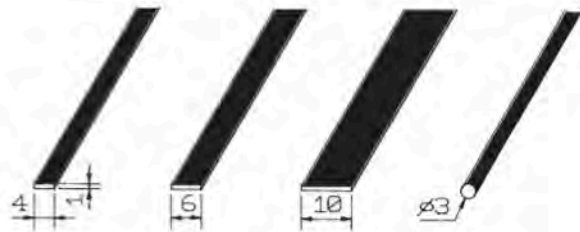

訂購編號

粒度	顏色COLOR	1 x 4 x 100 mm	1 x 6 x 100 mm	1 x 10 x 100 mm	ø 3 x 100 mm
180#	咖啡BROWN	BR104	BR106	BR110	BRD3B
250#	橘ORANGE	OR104	OR106	OR110	ORD3B
280#	黑BLACK	BL104	BL106	BL110	BLD3B
320#	水藍NAVY BLUE	NB104	NB106	NB110	NBD3B
400#	藍BLUE	B104	B106	B110	BD3B
500#	綠GREEN	G104	G106	G110	GD3B
700#	黃YELLOW	Y104	Y106	Y110	YD3B
1000#	粉紅PINK	P104	P106	P110	PD3B
1200#	紅RED	R104	R106	R110	RD3B

หินขัดน้ำมัน EDM และ DF

EDM OIL POLISHING STONES

ขนาด (นิ้ว)	ขนาด (มิลเมตร)	ราคา(EDM)	ราคา(DF)
1/16 * 1/4 * 6 "	1.6 * 6 * 150 MM.	99	118
1/16 * 1/2 * 6 "	1.6 * 13 * 150 MM.	105	126
1/8 * 1/4 * 6 "	3 * 6 * 150 MM.	105	126
1/8 * 1/2 * 6 "	3 * 13 * 150 MM.	112	136
1/4 * 1/4 * 6 "	6 * 6 * 150 MM.	128	154
1/4 * 1/2 * 6 "	6 * 13 * 150 MM.	182	218
3/8 * 3/8 * 6 "	10 * 10 * 150 MM.	225	270
1/2 * 1/2 * 6 "	13 * 13 * 150 MM.	270	325
1 * 1 * 6 "	25 * 25 * 150 MM.	850	924
1 * 2 * 6 "	25 * 50 * 150 MM.	1800	2000

GRIT # 120 , # 220 , # 320 , # 400 , # 600 , # 800 , # 1,000

石工用鑽石工具
Diamond Tools For Masonry

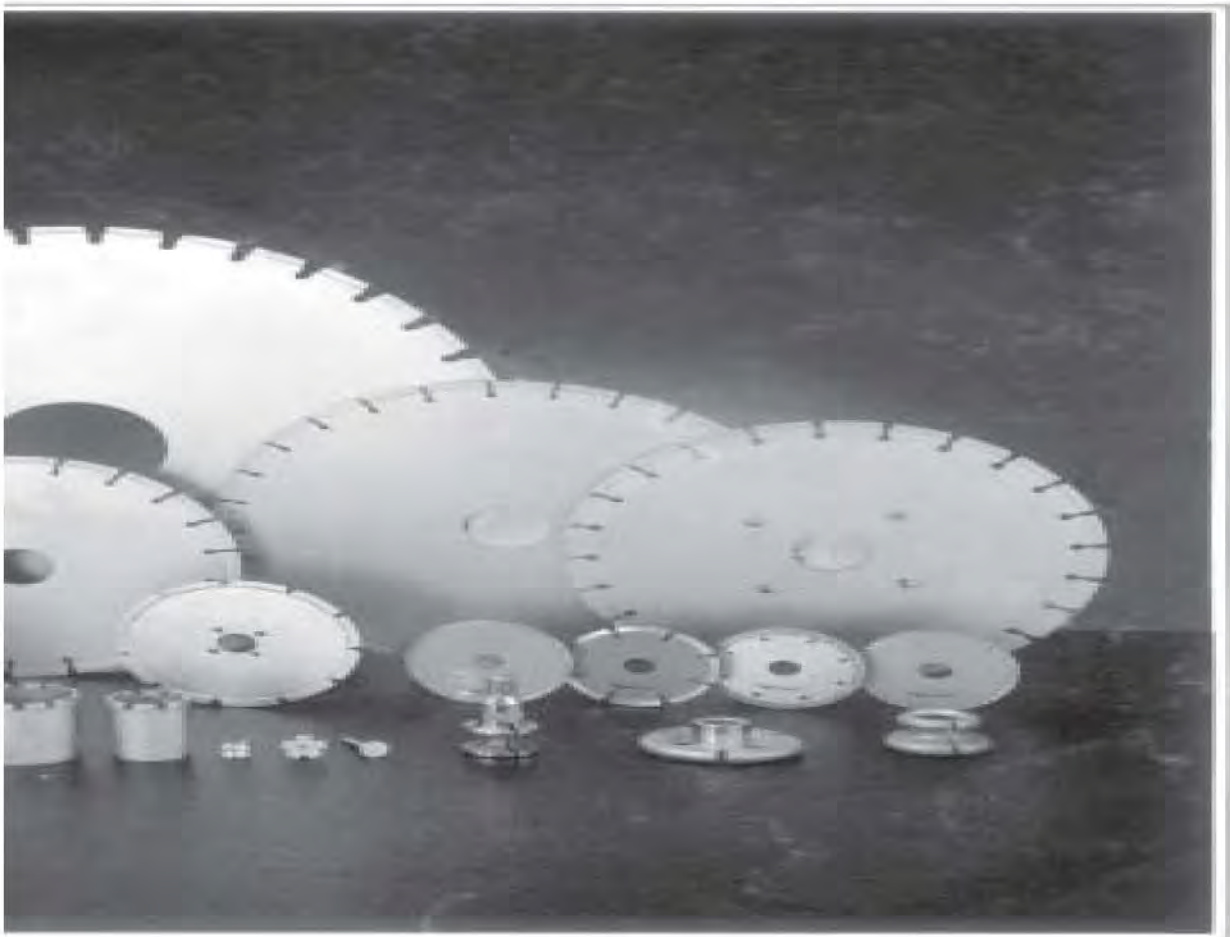

鑽石鋸片 / Diamond Saw Blade

K Type: 窄溝水滴型 (Narrow key hole slots)

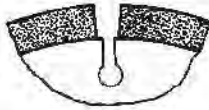

適合板材之切斷，以減少加工物之邊緣崩裂，一般用於較小外徑之鋸片。

Suit for edges cutting of slates, to reduce the chipping at corners or edges of work-piece. Usually, applied on saw blades of smaller diameter.



W Type: 寬溝U型 (Wide U Slots)

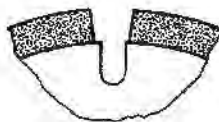

適合於石塊之切斷，或深切作業。

Suit for cutting the blocks or deep cutting operations.

用途：

1. 花崗石、大理石砂岩、石灰岩等之切斷。
2. 耐火磚之切割。
3. 柏油、水泥面之切割。

Applications:

1. For cutting the granite, marble, sandstone or limestone.
2. For cutting the refractory.
3. For cutting the concrete or asphalt.

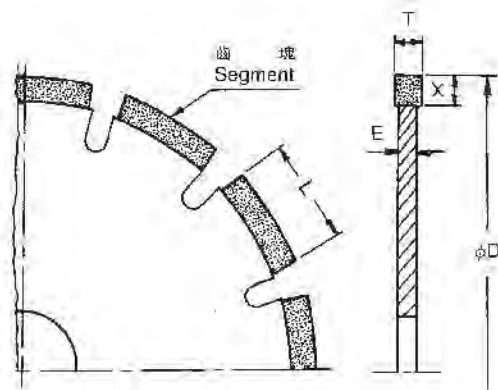

單位 (Unit): mm

編號 Order no.	φD	φH	E	總齒數 Nos. of segment		齒塊尺寸 Dimensions of segment		
				K type	W type	L	T	X
SBK-12	300 (12")	50	2.2	21	—	40	3	8.5
SBK-14	350 (14")	50	2.2	24	—	40	3	8.5
SBK-16	400 (16")	50	2.5	28	—	40	3.2	8.5
SBW-18	450 (18")	50	2.8	—	26	40	3.8	8.5
SBW-20	500 (20")	50	2.8	—	30	40	3.8	8.5
SBW-24	600 (24")	50	3.5	—	36	40	4.5	8.5
SBW-28	700 (28")	50	4.0	—	40	40	5	8.5
SBW-32	800 (32")	100	4.5	—	46	40	6	8.5
SBW-36	900 (36")	100	5.0	—	64	25	6.5	9
SBW-40	1000 (40")	100	5.0	—	70	25	6.5	9
SBW-44	1100 (44")	100	5.5	—	74	25	7	9
SBW-48	1200 (48")	100	5.5	—	80	25	7	9
SBW-52	1300 (52")	100	6.0	—	88	25	8	9
SBW-56	1400 (56")	100	6.0	—	92	25	8	9
SBW-60	1500 (60")	100	7.0	—	100	25	9	9
SBW-64	1600 (64")	100	7.0	—	108	25	9	9
SBW-72	1800 (72")	100	7.0	—	120	25	9	9
SBW-80	2000 (80")	100	8.0	—	128	25	10	9

說明：訂購時請指明欲切割工作物之材質，若有其他規格，敬請指明訂購。

- Remark: 1. Other specifications depend on your requirements.
2. When ordering, please specify the materials to be cut.

鑽石薄壁鑽頭 / Diamond Core Drill Bits

用途：

混凝土、磚牆、柏油、耐火磚等之鑽孔或取樣。

Applications:

To drill holes or to collect test pieces of concrete, brick, asphalt and refractory brick kilns.

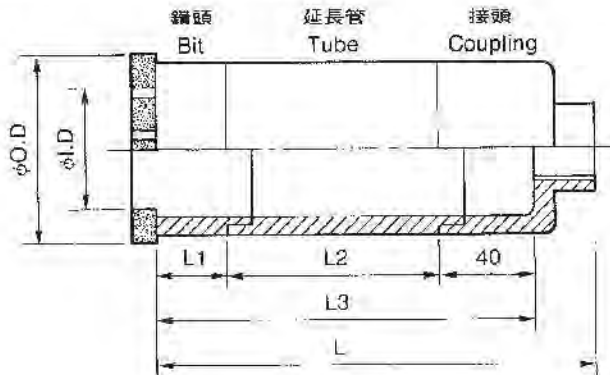

- O.D: 鑽頭外徑 / Outside diameter of bits
- I.D: 鑽頭內徑 / Inside diameter of bits
- L1: 鑽頭長度 / Bit length
- L2: 延長管長度 / Tube length
- L3: 有效鑽孔深度 / Effective drilling length
- L: 總長 / Total length

規格 / Specifications:

編號 Order no.	口徑 Bit name	尺寸/Dim. (mm) O.D-I.D	L1 (mm)	L2 (mm)	接頭 (mm) Coupling	L3 (mm)	L (mm)
MB-025	1"	28.1-19.1	35	280	-	315 (365)	415 (465)
MB-032	1¼"	33.7-24.7	40	(330)		320 (370)	420 (470)
MB-038	1½"	41.1-32.1		310 (360)			
MB-050	2"	53.2-44.2					
MB-064	2½"	64.8-55.8	70	270 (320)	40	350 (400)	410 (460)
MB-075	3"	77.6-68.6					
MB-089	3½"	90.1-81.1					
MB-100	4"	110.4-100.4	90	270	40	380 (430)	440 (490)
MB-125	5"	128.4-118.4					
MB-150	6"	160.4-150.4					
MB-175	7"	180.4-170.4	270	40	400	400 (450)	460 (510)
MB-200	8"	205.4-193.4					
MB-230	9"	230.4-218.4					
MB-250	10"	254.4-242.4				400	460

說明：1. 訂購時，除請指明鑽頭之編號外，並請指明延長管之長度或單獨購買鑽頭亦可。

2. 標準延長管之長度有300mm及350mm兩種，其它長度可訂製。

3. ()內之數字，表示採用350mm延長管時之長度。

Note: 1. When ordering, please specify the order no. of bit and the length of tube or just order the bits only.

2. There are two standard tube length available 300 & 350mm, others depend on your requirement.

3. Figures in () show the length of 350mm tube.

鑽石磨棒 / Diamond Mounted Wheels

用途 / Applications:

石材、陶瓷、石墨、碳纖、硬質橡膠、F.R.P.等之研磨。

Used for grinding the stones, F.R.P., ceramics, carbide, carbon, hard rubber, graphics, ...etc.

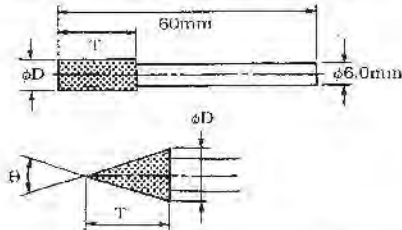

粒度 / Grit size:

#40/50 (D427)

#60/80 (D252)

其他粒度，歡迎訂製

Other grit size are available on request.



圖型																					
Order No.	BC80B*	BC100B	BC200*	BC300*	BC400*	BC500*	BC600*	BC700*	BC800*	BC900*	BC1000*	BC1200*	BC1500*	BC2000*	BC2500*	BC3000*	BC4000*	BC5000*	BC6000*	BC8000*	BC10000*
鑽石粒度(目)	8.0	10	4	10	6.5	8.0	10	6.5	8.0	10	6.5	8.0	10	6.5	8.0	10	6.5	8.0	10	6.5	8.0
鑽石列數(T)	—	—	20	—	—	—	—	—	—	—	—	—	—	—	—	—	—	—	—	—	—
角度(度)	—	—	20	—	—	—	—	—	—	—	—	—	—	—	—	—	—	—	—	—	—

說明：編號上有“*”記號者為標準組裝，10支一組，編號為BC-10。

1. The part no. denoted by asterisk is standard set collection, order no. BC-10.
2. Other collection or bulk package upon your requirement.

電鑄鋸片 / Electroplated Diamond Cutters.

用途 / Applications:

大理石、磁磚、F.R.P.、碳纖或石墨等之切割。

Used for cutting marble, tile, F.R.P., carbon or graphics.

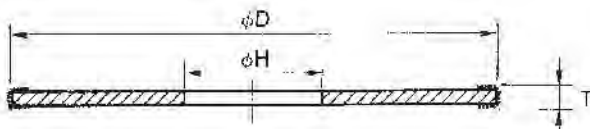

編號 Order no.	(mm) phi D	(mm) T	(mm) phi H	型式 Type
SP-085F	85	1.8	20.0	C,S,U
SP-100F	100	1.8	20.0	C,S,U
SP-115F	115	1.8	22.0	C,S,U
SPD-115J	115	2.5	22.2	D
SP-125F	125	1.8	22.0	C,S,U
SPK-125G	125	2.0	22.0	K
SPD-125J	125	2.5	22.2	D
SP-150F	150	1.8	22.0	C,S,U
SP-180F	180	2.2	25.4	C,S,U
SPD-180J	180	2.5	22.2	D
SP-200F	200	2.2	25.4	C,S,U
SP-230F	230	2.2	25.4	C,S,U
SP-250F	250	2.5	25.4	C,S,U
SP-300F	300	2.5	25.4	C,S,U

註：1. 其他孔徑及#40以外之粒度，訂購時請指明。

Note: 1. Other bore diameter (phi H) are available upon request.

2. Standard grit size is #40 (D427), others depend on request.

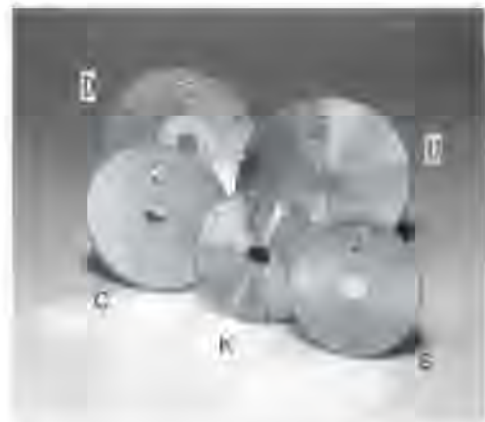

- C: 連續式 / Contious rim type
- S: 輻條式 / Spoke type
- U: U溝式 / U-slot type
- K: 水滴溝式 / Key hole slot type
- D: 皿形輻條式 / Dish spoke type

鑽石雕刻針 / Diamond Carving Instrument

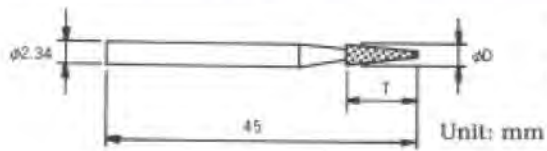









































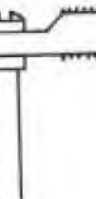









用途 / Applications:

牙科技工所齒模雕刻、玉石、寶石、半寶石、貝壳、珊瑚等之雕刻用。

Used for carving stones, jade, semiprecious, gem stones, seashell, coral or applied on dental laboratory.

Order No. D1 D2 D3 D4	A11 A12 A13	A21 A30	7A 8A
ϕD 1 2 3 4	1 1.5 1.5	2.5 3	7 8
T - - -	5 5 7	7 7	6 10
Order No. A20 A31 A14	TR 1R	KS RZ	
ϕD 2.5 3 2.5	1.5 1.5	3.5 4	
T 7 7 7	8 10	6 6	
Order No. T11 T12 T13	T30 1A 2A 2LA	3A 5A 6A	2LB
ϕD 1 1.5 2	3 2 2.5 2.5	3 4 5	2.5
T 4 4 4	4 8 12 10	10 10 10	12
Order No. 1LR 2R 2LR	3R 5R 6R 7R 8R	C3 C13 C23	
ϕD 1.5 2 2.5	3 4 5 7 8	0.9 1.5 2	
T 10 12 12	12 12 12 12 12	4 10 10	
Order No. 128A 148A 168A 198A	Kr5 Kr8 Kr9	K6 K10 KA	
ϕD 4 6 10 12	6 8 8	2 2.5 7	
T - - -	1.5 2 3	5 7 12	

鑽石雕刻針 / Diamond Carving Instrument

										
Order No.	10B	12B	13B	14B	16B	168B	168C	168C	168C	13nk
ϕD	2.7	4	5	6	10	10	10	10	10	5
T	-	-	-	-	-	-	-	-	-	-
										
Order No.	RT	10X	17X	18X	19X	23X	108N	128N	138N	138N
ϕD	5	1.8	4	6	10	16	2.5	4	5	5
T	7	0.5	0.8	1	1.6	2	-	-	-	-
										
Order No.	K25	K30	K35	K45	K50	K55	K60	20mA	20mA	20mA
ϕD	4	5	6	10	10	12	12	20	20	20
T	0.4	0.6	0.5	0.5	1	0.6	1	3.5	3.5	3.5
										
Order No.	13mB	16mC	16mB	16mB	10mA	13mA	16mA	10mA	13mA	16mA
ϕD	13	16	16	16	10	13	16	10	13	16
T	2.5	2.5	3.5	3.5	2.5	3.5	3.5	2.5	3.5	3.5
										
Order No.	88D	88D	88C	88C	88A	88A				
ϕD	22	22	22	22	22	22				
T	0.45	0.45	0.35	0.35	0.45	0.45				

聚晶鑽石・氮化硼切削工具
DIAMOND TURNING TOOLS

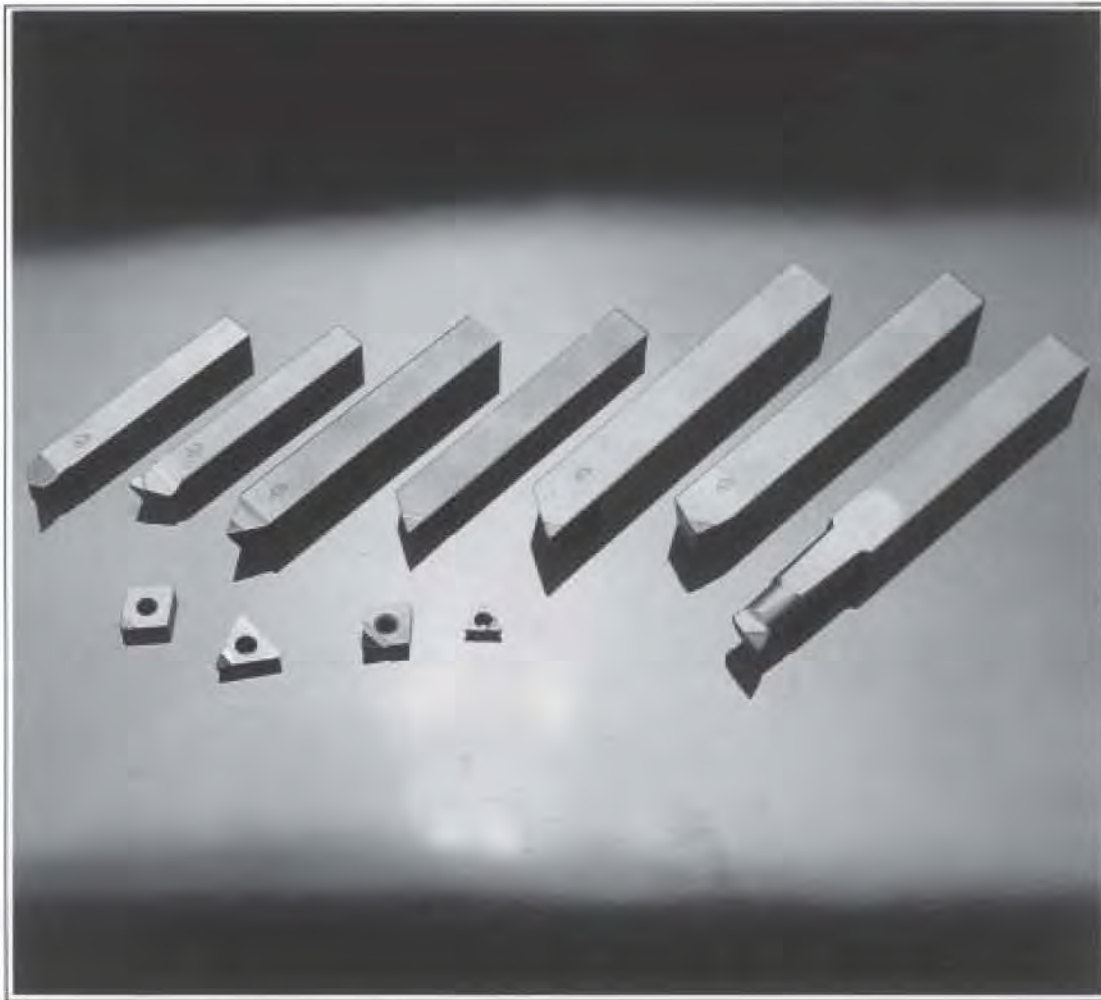

มีดกลึงเพชร PCD และ PCBN PCD & PCBN TURNING TOOLS



PCD และ PCBN มีความแข็งแรงและต่อต้านรอบสึกสูงกว่าเครื่องมือตัดอื่นๆ
ซึ่งได้เปรียบของลักษณะเด่นมีดังต่อไปนี้ :

อายุการใช้งานของเครื่องมือ, ควบคุมขนาด, สัดสวน, และความเผาะของผิว
หน้าวัสดุได้ดีกว่า, ลดต้นทุนในการใช้เครื่องจักร, และปรับปรุงเครื่องจักร
ให้มีประสิทธิภาพมากขึ้น

PCD & PCBN have higher hardness & abrasion resistance than other cutting tools
The advantages of these features are : improving tool's life, providing better
control over part size and surface finishes, reducing tool cost per machined
part, and improving machine productivity

ขอบเขตการใช้

• (PCD)

โลหะผสมอลูมิเนียม, โลหะผสมทองแดง, โลหะผสมธาตุโลหะแข็ง
คาร์ไบด์, และเซรามิค
เซียว หรือกึ่งคาร์ไบด์ และเซรามิค
โลหะผสมซิลิโคนอลูมิเนียมสูง
พลาสติกเสริมกำลัง, ยางแข็ง, วัสดุคาร์บอน, ตะกั่วดำ

• (PCBN)

เหล็กแข็ง (HRC 45-68)
เหล็กทนความร้อน
โลหะผสมชั้นเลิศ : โคบอลท์และนิกเกิลพื้นฐานโลหะชั้นเลิศ
เหล็กหล่อ : เหล็กเย็น, เหล็ก Meehanite
โลหะผสมเหล็ก : SCM, SNCM

Application :

• Polycrystalling Diamond (PCD)

Aluminum alloys, copper alloys, manganese alloys
Sintered carbide & ceramics
Green or semi-sintered carbide & ceramics
High-silicon aluminum alloys
Reinforced plastic, hard rubber, carbon, graphite

• Polycrystalling Cubic Boron Nitride (PCBN)

Hardened steels (HRC 45-68)
Tempering steels
Super alloys : Cobalt and nickel base super alloys
Cast iron : Chilled iron, Meehanite iron,
Sintered ferrous alloys : SCM, SNCM

Insert Shapes	Shape no.	Dimension (inch)					Angel
		IC	T	φd	R	a	
	VBGT 160402-00 160404-00 160408-00 160412-00	3/8"	.187"	.173"	.008" 1/64" 1/32" 3/64"	5°	
	VBGT 160402-07 160404-07 160408-07	3/8"	.187"	.173"	.008" 1/64" 1/32"	5°	
	VCGT 160402-00 160404-00 160412-00	3/8"	.187"	.173"	.008" 1/64" 3/64"	7°	
	VCGT 160402-07 160404-07 160408-07 160412-07	3/8"	.187"	.173"	.008" 1/64" 1/32" 3/64"	7°	
	CCGT 90T304-00 90T304-07	3/8"	.156"	.173"	1/64" 1/64"	7°	
	CCGT 120404-00 120408-00	1/2"	.187"	.173"	1/64" 1/64"	7°	
	CCGT 120404-07 120408-07	1/2"	.187"	.217"	1/64" 1/32"	7°	

Insert Shapes	Shape no.	Dimension (inch)					Angel
		IC	T	φd	R	a	
	DCGT 11T302-00 11T304-00	3/8"	.156"	.173"	.008" 1/64"	7°	
	DCGT 11T302-07 11T304-07	3/8"	.187"	.173"	.008" 1/64"	7°	
	DCGT 070202-00 070204-00	1/4"	.093"	.11"	.008" 1/64"	7°	
	TNGA 160404-11 160408-11	3/8"	.187"	.15"	1/64" 1/32"	0°	
	TCGT 110204-00	1/4"	.093"	.136"	1/64"	11°	
	TPGT 080204-00 090204-00 110304-00	3/16" 7/32" 1/4"	.093" .093" .150"	.098" .118" .129"	1/64"	7°	
	TPG 221 TPG 222 TPG 321 TPG 322	1/4" 3/8"	1/8"		1/64" 1/32" 1/64" 1/32"	11°	

P.C.D. FOR CYLINDER & PISTON

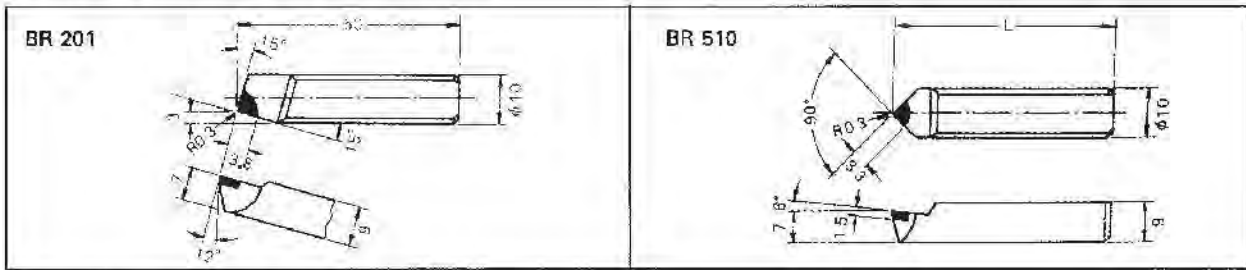

รายละเอียดขนาด / SPECIFICATIONS :

Unit : mm

	เบอร์สั่ง Order no.	เบอร์สั่ง Order no.	W	H	L	R	V'	S
<p>31</p>	B4612-4G	PCBN	16	16	120	0.4	0	0
	B4613-4G	PCBN	19	19	140	0.4	0	0
<p>33</p>	D6732-5A	PCD	16	16	120	0.5	0	0
	D6733-5A	PCD	19	19	140	0.5	0	0
	B6630-4G	PCBN	10	10	80	0.4	0	0
	B6631-4G	PCBN	13	13	100	0.4	0	0
	B6632-4G	PCBN	16	16	120	0.4	0	0
	D6530-3F	PCD	10	10	80	0.3	10	0
	D6531-3F	PCD	13	13	100	0.3	10	0
D6532-3F	PCD	16	16	120	0.3	10	0	
<p>34</p>	D6540-3F	PCD	10	10	80	0.3	10	0
	D6541-3F	PCD	13	13	100	0.3	10	0
	D6542-3F	PCD	16	16	120	0.3	10	0
<p>35</p>	D6752-5A	PCD	16	16	120	0.5	0	0
	D6753-5A	PCD	19	19	140	0.5	0	0
	B6650-4G	PCBN	10	10	80	0.4	0	0
	B6651-4G	PCBN	13	13	100	0.4	0	0
	B6652-4G	PCBN	16	16	120	0.4	0	0
	D6550-3F	PCD	10	10	80	0.3	10	0
	D6551-3F	PCD	13	13	100	0.3	10	0
D6552-3F	PCD	16	16	120	0.3	10	0	
<p>36</p>	D6772-5A	PCD	16	16	120	0.5	0	2
	D6773-5A	PCD	19	19	140	0.5	0	2
	B6672-4G	PCBN	16	16	120	0.4	0	2
	B6673-4G	PCBN	19	19	140	0.4	0	2
	D6571-3F	PCD	13	13	100	0.3	10	2
	D6572-3F	PCD	16	16	120	0.3	10	2

Cosmic

MAIN PRODUCTS

DIAMOND & CBN GRINDING WHEELS

DIAMOND DRESSING TOOLS

PCN & PCBN TURNING TOOLS

DIAMOND TOOLS & FOR MASONRY

SAW BLADE, WHEELS, CORE DRILL & CBN TOOLS.

ELECTROPLATED DIAMOND & CBN TOOLS

FILES, MOUNTED POINTS, WHEEL & DENTAL INSTRUMENT.

DIAMOND POLISHING TOOLS

COMPOUNDS, POWDERS, FOILS & HAND STONES.

เราเลือกสรรคํอุปกรณ์ที่มีมาตรฐาน

เพื่อการผลิดงานเจียรแต่งด้านอุตสาหกรรม ให้ได้รูปแบบที่ดีของตลาด

เราภูมิใจที่เป็นส่วนหนึ่งในการสร้างสรรค์งานในประเทศ

ผู้ผลิตและจำหน่ายเครื่องมือ อุปกรณ์เคลือบชุบเพชร

บริษัท คอสมิก ไดมอนด์ อินดัสเทรียล จำกัด

COSMIC DIAMOND INDUSTRIAL CO., LTD.

302/44 ซ.ลาดพร้าว 71 แขวง/เขต วังทองหลาง กรุงเทพฯ 10310

302/44 Soi. Ladprao 71 Wangthonglang, Bkk. 10310

Tel : 02-931-3420-4 Fax :02-931-2154